

UK

HE-VA

Operating Instructions
Spare Parts List
Declaration of Conformity

as it looks



As good as it looks



As good as it looks

As good as it looks



As good as it looks

Warning: Be sure to read the operation instructions before using the machine.

Stealth

Rigid: 3,00 - 3,50 - 4,00 m
Hydraulic: 4,00 - 5,00 - 6,00 m



N. A. Christensensvej 34
DK-7900 Nykøbing Mors

Tel: 97724288
www.he-va.com

Contents

EC DECLARATION OF CONFORMITY	5
Delivery check.....	6
Machine Description	6
Range of Application	6
Technical specifications.....	6
Safety instructions for Stealth	7
Safety and Instructions on Hydraulics	8
Transport on public roads	8
Front axle load.....	8
Labels on the machine.....	9
Start-up of the machine	10
General	10
Attachment and uncoupling (rigid machines).....	10
Attachment and uncoupling (hydr. machines).....	10
Settings and adjustment.....	11
Stone protection.....	11
Hydraulic automatic release system	12
Replacement of wearing point	13
Scraper.....	14
Maintenance.....	15
Lubrication.....	15
Spare parts list	18
Drawbar	18
Frame 3m - 4m (rigid).....	20
Frame 4m - 6m (hydr).....	22
Wheel frame (only for hydr machine)	25
Rollers.....	26
Scraper.....	28
Easy Draft tine w/Quick-Push shear bolt.....	29
Easy Draft tand m/hydr. automatudløsning.....	30
Disc-opens (rigid).....	32
Disc-opens 4m - 6m (hydr)	36
Plateau (rigid)	38
Plateau (hydraulic).....	40
LED-Light.....	42
Hydraulics	44
Drawbar and Wheel frame	44

Wing.....	45
Disc-opens (rigid).....	46
Disc-opens (hydr).....	48
Depth control of roller (rigid)	50
Depth control of roller (hydr)	51
Hydr. for automatic release system (rigid).....	52
Hydr. for automatic release system (hydr).....	54
Plateau.....	56
Notes	57



EC DECLARATION OF CONFORMITY

in accordance with the EU Machinery Directive 2006/42/EC
applicable as from December 29th 2009:

HE-VA ApS
N. A. Christensensvej 34,
DK-7900 Nykøbing Mors

hereby confirms that the following machine has been manufactured in accordance with the Council
Directive 2006/42/EC.

In addition, the following harmonized EU standard has been used:

ISO 12100 Machine safety, general design principles, risk assessment and risk reduction.

The declaration comprises the following machine:

Stealth – 3,0m – 3,5m – 4,0m (Rigid)
Stealth – 4,0m – 5,0m – 6,0m (Hydraulic)

Nykøbing, April 1st 2020

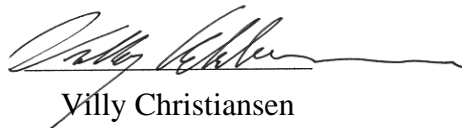

Villy Christiansen

The undersigned is furthermore authorised to compile technical documentation for the above
machine. The design is subject to modification without notice.

Delivery check

Upon delivery to the dealer/supplier as well as to the customer, check the Sub-Tiller Stealth for possible damages.

Machine Description

Range of Application

Stealth is a universal sub-soiler, especially suited for low disturbance sub-soiling. Stealth effectively loosens the structural damages caused by heavy machinery. A serrated disc placed in front of each tine slices through the grass or organic material, allowing the tine to loosen the soil down to a depth of 30 cm. without making significant disturbance on the surface of the ground

Stealth is available with the Ø450/500 mm Star roller, 600mm V-profile roller, and with the Ø550 mm Square tube roller.

The packer roller acts as depth control, for a uniform packing of the ground. The Stealth is designed for 450-500-550mm leg spacing, but with a couple of special tineholders it is possible to set the machine to 750mm leg spacing as well.

With infinitely variable tine adjustment, the spacing of the tines can be easily suited for all working conditions. Stealth applies to all soil types.

Stealth can be equipped with the HE-VA Multi-Seeder, allowing for till-seeding rape, grass or cover crops.

Stealth is mounted in the tractor's three-point suspension, and the hydraulic depth control via the packer roller is controlled by the hydraulic system of the tractor. In order to achieve optimum control you should be aware of the tractor wheel type. Under certain circumstances, a mounting of twin wheels is recommendable.

Technical specifications

Model	3.0 m Rigid	3.5 m Rigid	4.0 m Rigid	4,0 m Hydr.	5.0 m Hydr.	6.0 m Hydr.
Working width	3m	3,5m	4m	4m	5m	6m
Transport height				2,37m	2,87m	3,37m
Transport width	3m	3,5m	4m	2,54m	2,54m	2,54
Power requirement HP						
Requirement - double acting oil outlets	2	2	2	3	3	3
Requirement - single acting oil outlets (only Hydraulic automatic release system)	1	1	1	1	1	1
No. of tines	5/6/7	6/7/8	7/8/9	7/8/9	9/10/11	11/12/13
Weight roller						
Square tube roller w/Quick-Push shear bolt	kg	kg	kg	kg	kg	kg
Square tube roller w/hydraulic automatic release system	kg	kg	kg	kg	kg	kg
V-profile roller w/Quick-Push shear bolt	kg	kg	kg	kg	4050kg	kg
V-profile roller w/hydraulic automatic release system	kg	kg	kg	kg	kg	kg
Star roller w/Quick-Push shear bolt	kg	kg	kg	kg	kg	kg
Star roller w/hydraulic automatic release system	kg	kg	kg	kg	kg	kg
Syncrone roller w/Quick-Push shear bolt	kg	kg	kg	kg	kg	kg
Syncrone roller w/hydraulic automatic release system	kg	kg	kg	kg	kg	kg

Stealth complies with DS/ISO 11001-1, three-point suspension.

Safety instructions for Stealth

Do not start-up the machine if there are persons in exposed positions* within a hazardous area**.

When persons are in exposed positions (e.g. in connection with adjustment, maintenance, attachment and uncoupling), the following conditions must be observed:

1. The machine must be lowered to firm ground.
2. The hydraulics must be relieved.
3. The tractor must be stopped and the key removed from the ignition switch.
4. The driver must ensure that no persons are staying in exposed positions during the operation.

* Person in exposed position: Any person who is staying wholly or partly within a hazardous area.

** Hazardous area: On and under the machine within a distance of 4 m from the machine.

Most accidents that happen in connection with the operation, transport and maintenance of machines are caused by non-compliance with the most elementary safety conditions. Therefore, it is vital that anybody working at the machine carefully complies with the safety instructions as well as other instructions applying to the machine.

The machine should only be operated, maintained and repaired by persons, who are familiar with this work and who are further familiar with the possible elements of danger with this particular machine.

ATTENTION !! Rotary parts and loose clothes are a dangerous combination.

IMPORTANT !! In connection with the risk of parts falling down, it may endanger the lives of persons staying on the base frame of the machine, when it is operated attached to a tractor.

IMPORTANT !! In connection with transport and machine storage, the safety lock must be activated

Safety and Instructions on Hydraulics

1. The maximum working pressure is 225 bar.
2. It is advisable to label the attachment parts at hydraulic connections between the tractor and the tool in order to eliminate incorrect operation!
3. When checking for hydraulic leaks, use suitable safety wear (eye protectors, gloves, etc.) High-pressure hydraulic oil may penetrate the skin and cause dangerous injuries. In case of injury, consult a doctor immediately. **RISK OF INFECTION!**
4. Before operating the hydraulics, lower the machine to firm ground. Relieve the hydraulics, stop the motor and remove the ignition key.
5. Check the hydraulic hoses on a regular basis, however, every six months as a minimum due to any cracks, wear and tear, etc. Replace any defective hoses immediately.

The life of hydraulic hoses is maximum 5 years.
New hydraulic hoses must meet the manufacturer's requirements.

Transport on public roads

Check before transport on public roads that the attachment of the machine at the tractor is in accordance with the local rules and regulations in force (permitted total weight, permitted axle load, transport width, lights, warning signs, etc.).

Front axle load

After the attachment of the machine and at maximum load, the driving properties of the tractor must be ensured. Check that the front axle is sufficiently loaded. As a minimum, the front axle load must be 20% of the tractor weight. Permitted axle load and permitted total weight for the tractor must always be observed.

NB! The driving, controlling and braking properties are affected by the attached machine combination

Labels on the machine



Study the Operating Instructions thoroughly before any operation of the machine and observe all safety instructions.



Plate with number and year of manufacture

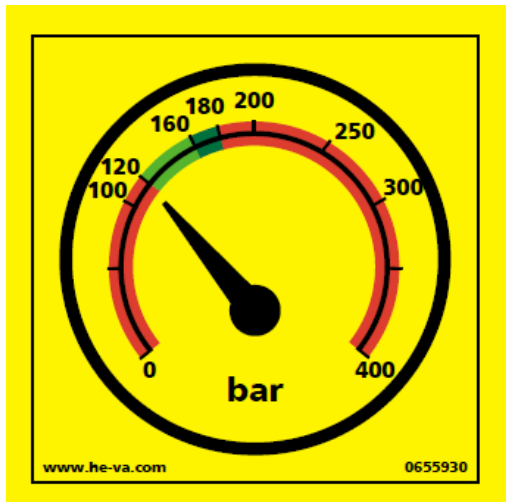

Correct hydraulic pressure on the release system

IMPORTANT!

All bolts must be tightened after the first few hours of operation, otherwise our guarantee will not apply.

IMPORTANT!

Resserrer tous les boulons et écrous après la première mise en marche. Le cas échéant nos obligations de garantie seront à considérer comme nulles.

WICHTIG!

Alle Muttern nach kurzem Gebrauch nachziehen. Bei Nichtbeachtung entfallen Gewährleistungsansprüche.

VIGTIG!

Efterspænd alle møtrikker efter kort tids brug. Hvis dette ikke overholdes, bortfalder vore garantiforpligtelser.

Tighten up all bolts regularly. If this is not performed, our guarantee obligations will no longer apply

Start-up of the machine

General

Hydraulic Hose Colour scheme	
Colour (Cable ties)	Function
Red	Trailing wheels height adjustment
Blue	wing folding
Yellow	Roller depth adjustment
Green	Disc Depth Adjustment
Black	Hydraulic automatic release system

Attachment and uncoupling (rigid machines)

1. Under normal circumstances attach the tractor in the lowest lifting points of the machine both as regards the lifting arms and the top link.
2. When the machine is to be parked and uncoupled from the tractor, it is important, that the roller is placed in the lowest position, so that the machine is placed stably.
3. When uncoupling, relieve the tractor's oil outlet, and the machine's quick couplings can be uncoupled without pressure. The hydraulic cylinder which controls the roller is equipped with a pilot-controlled check valve which hermetically cuts off the oil for the hydraulic cylinder, meaning that it is locked in the chosen position regardless of the tightness of the quick couplings.

Attachment and uncoupling (hydr. machines)

1. Be aware that the machine is to be attached und uncoupled to the tractor in transport position.
2. When the machine is hanging on the tractor, the support stands be raised to the top Position
3. The roller has to be placed in the lowest position otherwise problems might occur during the folding.

From transport to working position:

1. The machine is to be raised to max. transport height.
2. The depth adjusting cylinder is placed at the top.
3. Now unfold the wing sections. **Important** When unfolding the wings, the locking claw must first be relieved by activating the folding function, until the wings rest at the stop on the center frame. When the unfolding function is activated, the locking claw then first will open, after which the side joints unfold.
4. Adjust the working depth.

From working to transport position:

1. Raise the machine to max. transport height.
2. The depth adjusting cylinder (the roller) is placed at the top.
3. Now the wing sections are folded together into transport position.  Be sure that the locking claws lock the wing sections.

Settings and adjustment

Stone protection

Quick-Push shear bolt.

When the shear bolt is broken and the tine has been released, place the shear bolt one notch forward before the machine can operate again

 **Important: All activities under the machine are deprecated when the shear bolt is being moved or changed.**

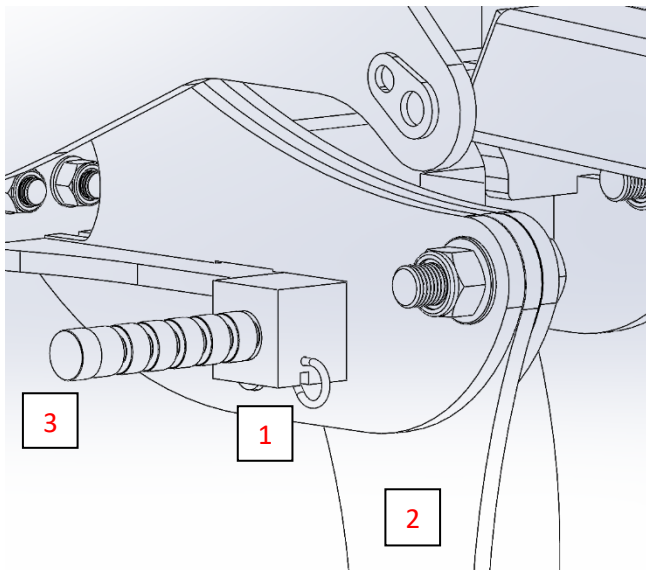

Pull out the R-clip (Pos. 1)

Pull the tine back to normal working position (Pos 2.)

Push the shear bolt (Pos. 3) one notch forward to a new position in the tine. Do not push the bolt totally through (it can be necessary to remove soil etc. from the hole in the tine)



Push back the R-clip (Pos. 1), so that it locks the sheare bolt in its place, and the machine is ready for operation

When the shear bolt is broken for the eighth time, it is used up. Be aware that the shear bolt must **never** be shorter than 65 mm.

When a new shear bolt is mounted it is important that it is placed rightly. The end of 40 mm (Pos. 3) is to turn away from the tine.

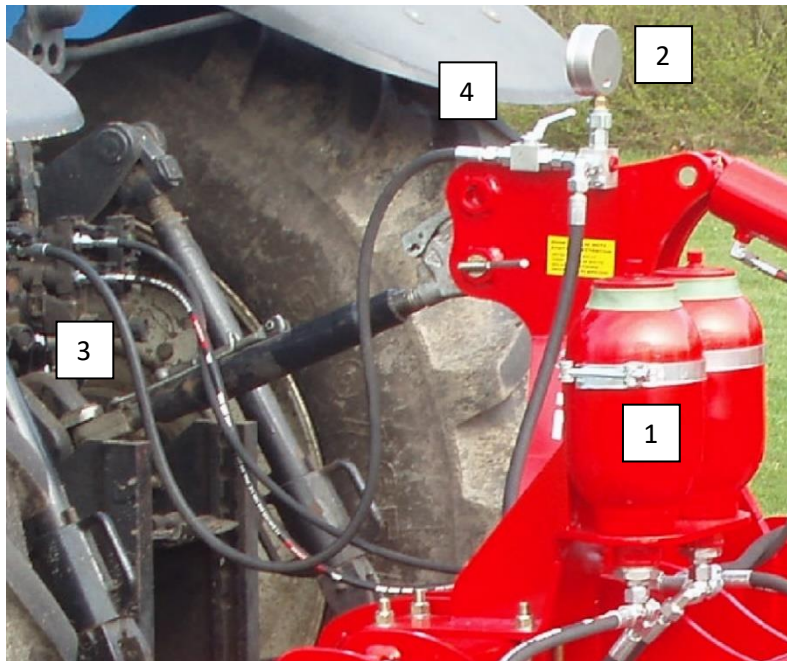
Hydraulic automatic release system



1. Before each season it has to be controlled, that the gas pressure in the accumulator (Pos.1) is 110 bars.  This requires special tools and can only be performed by an authorized dealer.
2. Before the start-up of the machine the hydraulic pressure in the closed hydraulic stone protection system has to be controlled on the machine's pressure gauge (Pos. 2). The pressure has to be **minimum 120 bar** and must not exceed 160 bar.
3. **IMPORTANT** – the hydraulic pressure is to be controlled continuously and must never be under 120 bar.
4. If there is a need to adjust the working pressure, follow the below instructions:
 - a. Mount the quick coupling of the hydraulic hose (Pos. 3) in the tractor's oil outlet.
 - b. Turn on the ball valve (Pos. 4), and the working pressure can now be adjusted up or down with the tractor's oil outlet.
 - c. When the desired pressure is achieved, turn off the ball valve again (Pos. 4), and the tractor's hydraulic system is relieved before the quick coupling (Pos. 3) is dismantled, and placed in the parking device of the machine
5. During the operation of the machine the tine is swinging automatically to the rear if it meets an obstacle. In normal circumstances the tine will automatically return to the working position again after having passed the obstacle. At extreme obstacles and/or soil conditions it might be necessary to stop and eventually lift the machine from the soil.
 It is important that no persons are near to the machine as the tine is returning to the working position with high speed and might throw with soil and stones.

Replacement of wearing point

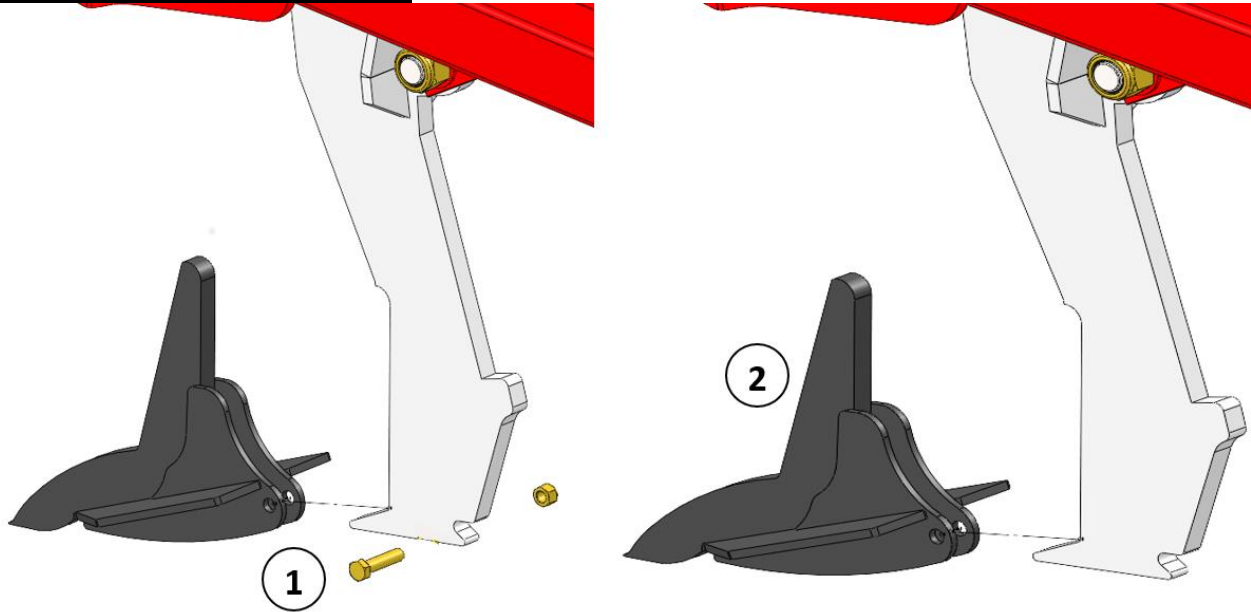

Before working with the wearing points, the machine must be secured. This can be performed by placing trestles under the main frame or by supporting the roller.

The wearing point might fall off when the shear bolt is removed - risk of foot or leg injury! .

1. Dismount bolt (Pos. 1) by means of 2 pcs. spanners.
2.  The wearing point might fall off, when the shear bolt is removed – risk of foot or leg injury.
3. Dismount the wearing point by pushing it forward. This might be difficult due to entrance of soil, and it might be a good idea to use a hammer.

Mount the new wearing point (Pos. 2), by pushing it to the rear and then into place

4. Check the bolt for any damages and replace if required. **Reorder the original bolt by replacing. It is a special bolt that secure that the wings isn't tightened**
5. Mount the bolt (Pos. 1), lubricate and tighten it to 20 Nm.
Be careful not to tighten the bolt too much, as it might damage the wearing point!

Scraper

The Stealth has special designed scrapers among the packer rings on the V-profile roller. To avoid unnecessary wear and to obtain the best scraper effect it is important to check the centering of the scrapers every day

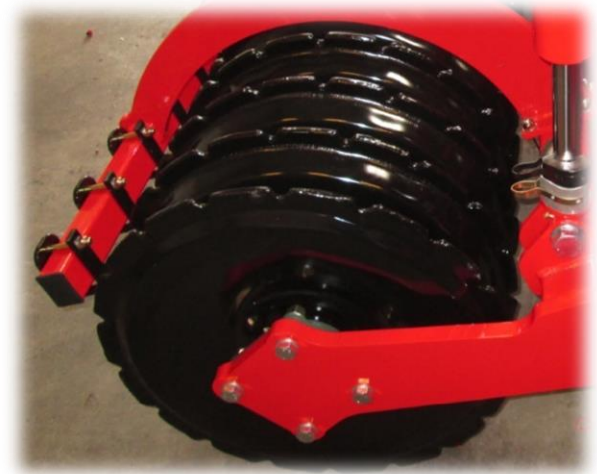

Maintenance

- After 10 hours of operation, retighten the machine.
Check hydraulic hoses, fittings and cylinders for leaks and retighten. See table below.
- Furthermore, check on a regular basis that all bolts are tightened.
- Before the winter storage, wash and lubricate the machine. If you use high-pressure cleaner, do not spray directly on the ball bearings. After the washing, you may spray the machine with oil.

Maximum torque in Nm. w/lubricated thread			
Metric thread	Quality 8.8	Quality 10.9	Quality 12.9
M10x1,5	47	65	79
M12x1,75	81	114	136
M14x2,0	128	181	217
M16x2,0	197	277	333
M18x2,5	275	386	463
M20x2,5	385	541	649
M22x2,5	518	728	874
M24x3,0	665	935	1120
Wheel bolt M18x1,5 fine thread		385	
Wheel bolt M22x1,5 fine thread		550	

Lubrication

For lubrication, maintenance and repair, lower the Stealth, put the brakes of the tractor on and stop the motor.

Typically, the lubrication points are located by the spring release, by the roller bearings, by the cylinders and the wing sections hinges.

The machine must be lubricated after 10 working hours as well as after cleaning in order to press out any water and dirt.

Note! XO

However, the double-sealed ball bearings in the roller should only be lubricated every 20 working hours and by 1-2 strokes so that the sealing rings

Important!

Oil, type Hydro Texaco HD32 has been filled in the hydraulic system.

Points of lubrication

Rigid Models

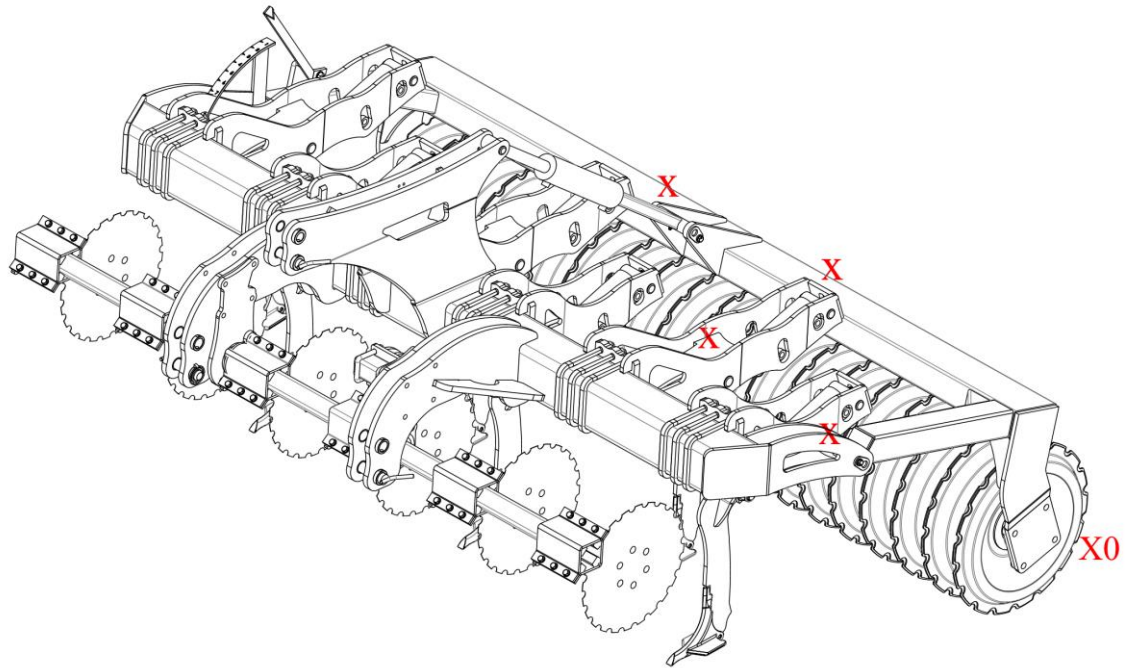

Hydraulic Models

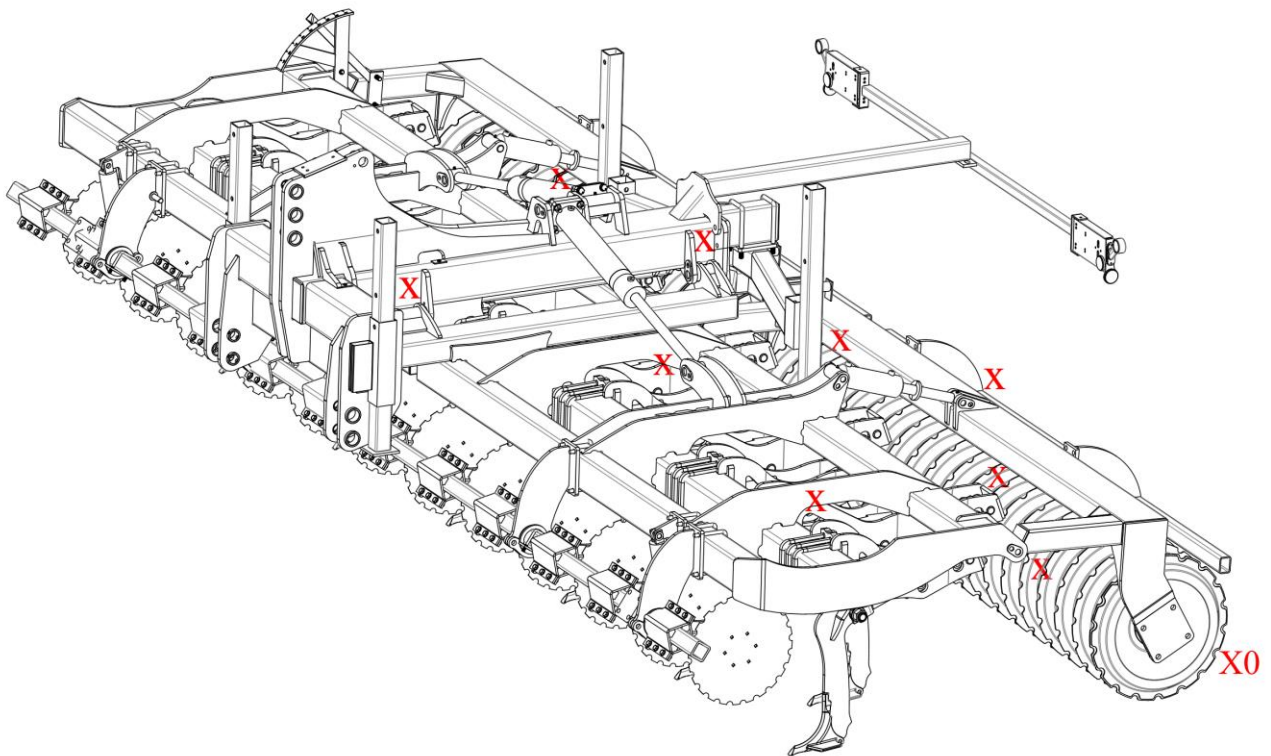

Spare parts list

Drawbar

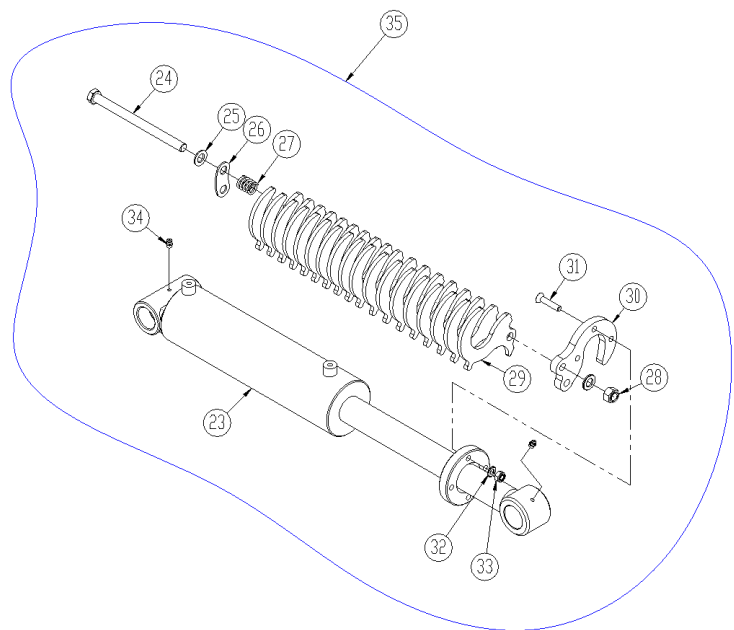
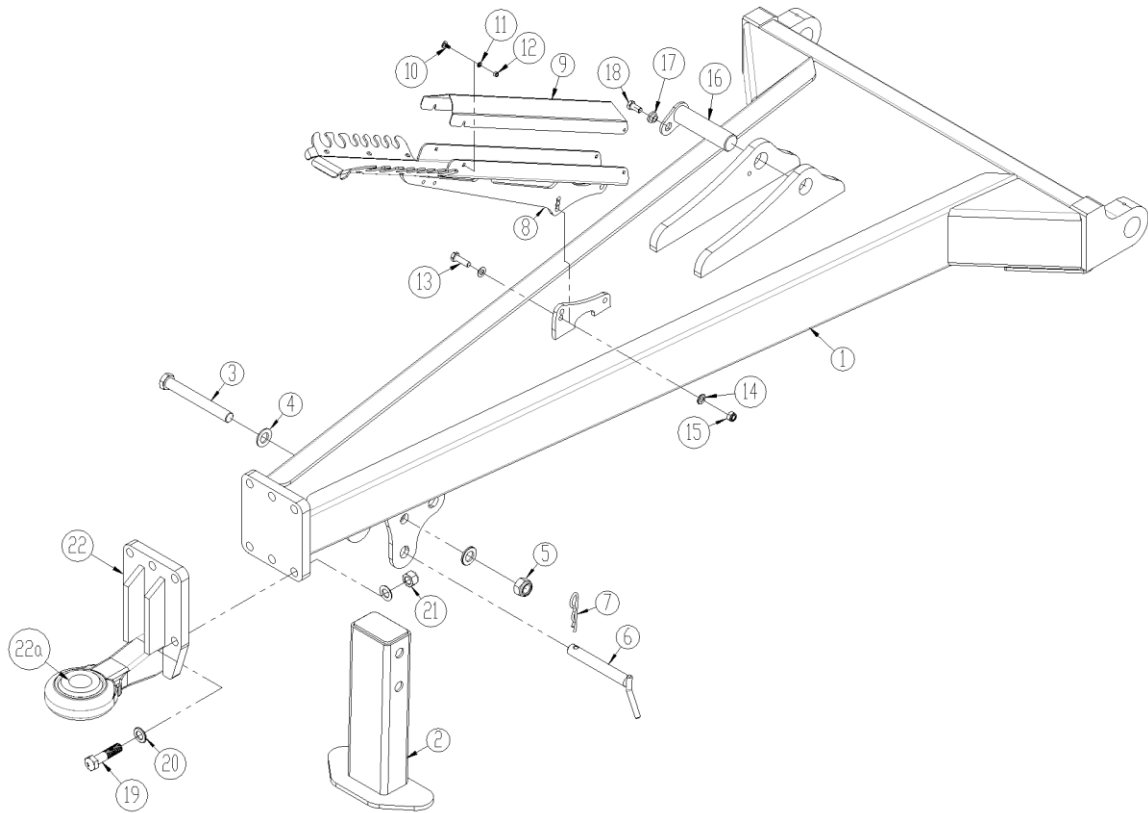

Pos.	Item no.	Designation	No.
1	1285139	Drawbar Kat. 3	1
2	1285146	Support leg	1
3	0236500	Bolt M24x190 8.8	1
4	0272330	Facet plate Ø24 mm	4
5	0264130	Locking nut M24	1
6	69525155B	Pin Ø25 L=155	1
7	0377600	R-clip Ø6	1
8	7345006	Horse holder, large	1
9	7345003	Screen for hose holder	1
10	0246060	Carriage bolt M6x16 8.8	4
11	0272240	Facet plate Ø6 mm	4
12	0264040	Locking nut M6	4
13	0235360	Bolt M12x40 8.8	2
14	0272270	Facet plate 12mm	4
15	0264070	Locking nut M12	2
16	1145304	Pin Ø40 L=160	1
17	630532600	Lock bush for pin head	1
18	690101101	Bolt M12x25 8.8	1
19	690103069	Bolt M20x80 10.9	6
20	0272310	Facet plate Ø20	12
21	0264110	Locking nut M20	6
22	630757111	Towing eye, Kat. 4, Ø39 mm	1
	630757112	Towing eye, Kat. 4, Ø51 mm	1
	630757113	Towing eye, Kat. 4, Ø71 mm	1
22a	630757132	Ball for Towing eye Ø33	
	630757106	Ball for Towing eye Ø39	
	630757107	Ball for Towing eye Ø51	
	630757108	Ball for Towing eye Ø71	
23	7345174	Cylinder 110/50-330 Ø40/Ø45	1
23a	690200311	Gasket set 110/50	
24	0236010	Bolt M16x220 8.8	2
25	0272290	Facet plate Ø16	4
26	7345082	Plade 3mm	1
27	0431570	Compression springs Ø3,2 x Dm 22 x Lo 50 x Nt 8	1
28	0264090	Locking nut M16	2
29	7345081	Distance plate 8 mm	18
30	7345080	Monting plate f/distance plate	1
31	0227852	Bolt indiv. 6-kt M10x50 8.8	3
32	0272260	Facet plate Ø10	3
33	0264060	Locking nut M10	3
34	0432510	Lubricating nipple M8	2
35	7345185	Cylinder w/Distance plate (complete)	

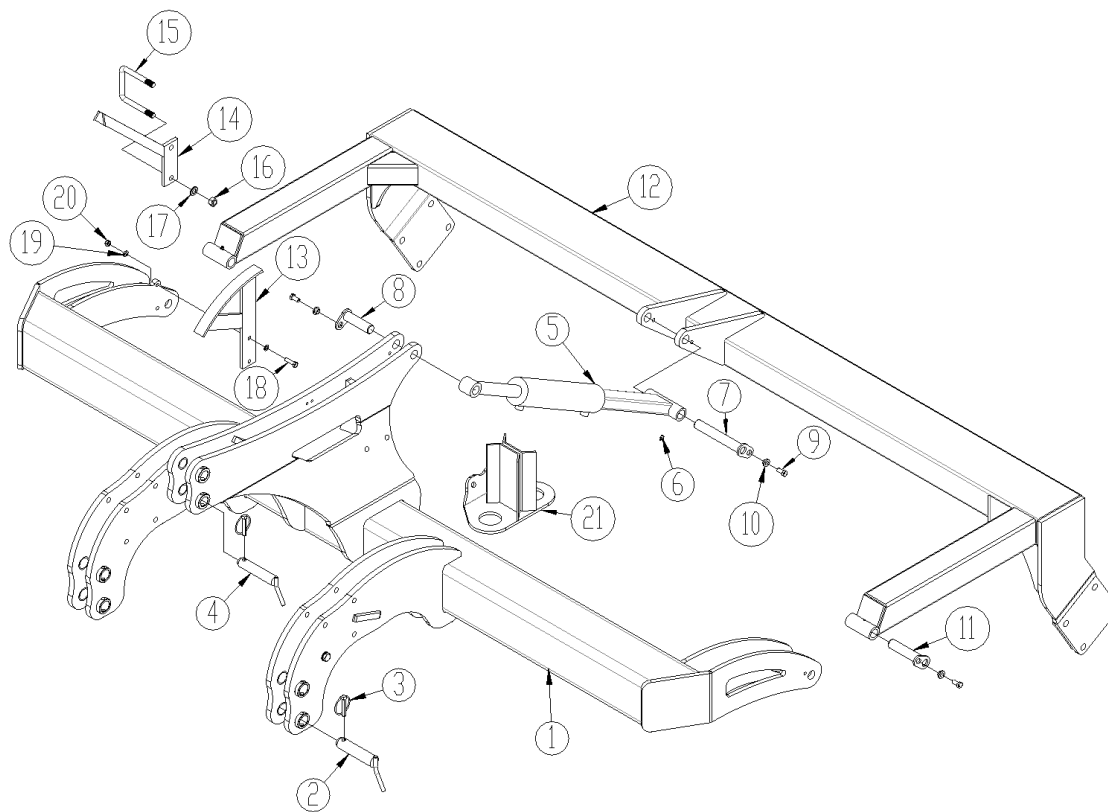
Frame 3m - 4m (rigid)

Pos.	Item no.	Designation	3,0m	3,5m	4,0m
1	645440010	Frame	1		
	645440030	Frame		1	
	1165358	Frame			1
2	69537129B	Pin for lift arm Ø37 L=129 (KAT.III)	2	2	2
3	690134008	Ring pin Ø11,5	3	3	3
4	69532129B	Pin for top link Ø32 L=129 (KAT.III)	1	1	1
5	645410007	Cylinder 80/20x280	1	1	1
	690200143	Gasket set			
6	0432510	Lubricating nipple M8			
7	69430200G	Pin Ø30 L=200	1	1	1
8	69430107G	Pin Ø30 L=107	1	1	1
9	690101101	Bolt M12x25 8.8	4	4	4
10	630532600	Lock bush for pin head	4	4	4
11	69430145G	Pin Ø30 L=145	2	2	2
12	645000027	Roller bar	1		
	645000156	Roller bar		1	
	645000157	Roller bar			1
13	645000162	Scale for depth control	1	1	1
14	645000165	Pointer for depth control	1	1	1
15	0382160	U-bolt M16x100x100x100	1	1	1
16	0264090	Locking nut M16	2	2	2

Pos.	Item no.	Designation	3,0m	3,5m	4,0m
17	0272290	Facet plate Ø16	2	2	2
18	0235070	Bolt M10x40mm 8.8	2	2	2
19	0272260	Facet plate Ø10	2	2	2
20	0264060	Locking nut M10	2	2	2
21	1165341	Support for accumulator (2 accumulator)	1	1	1

Frame 4m - 6m (hydr)

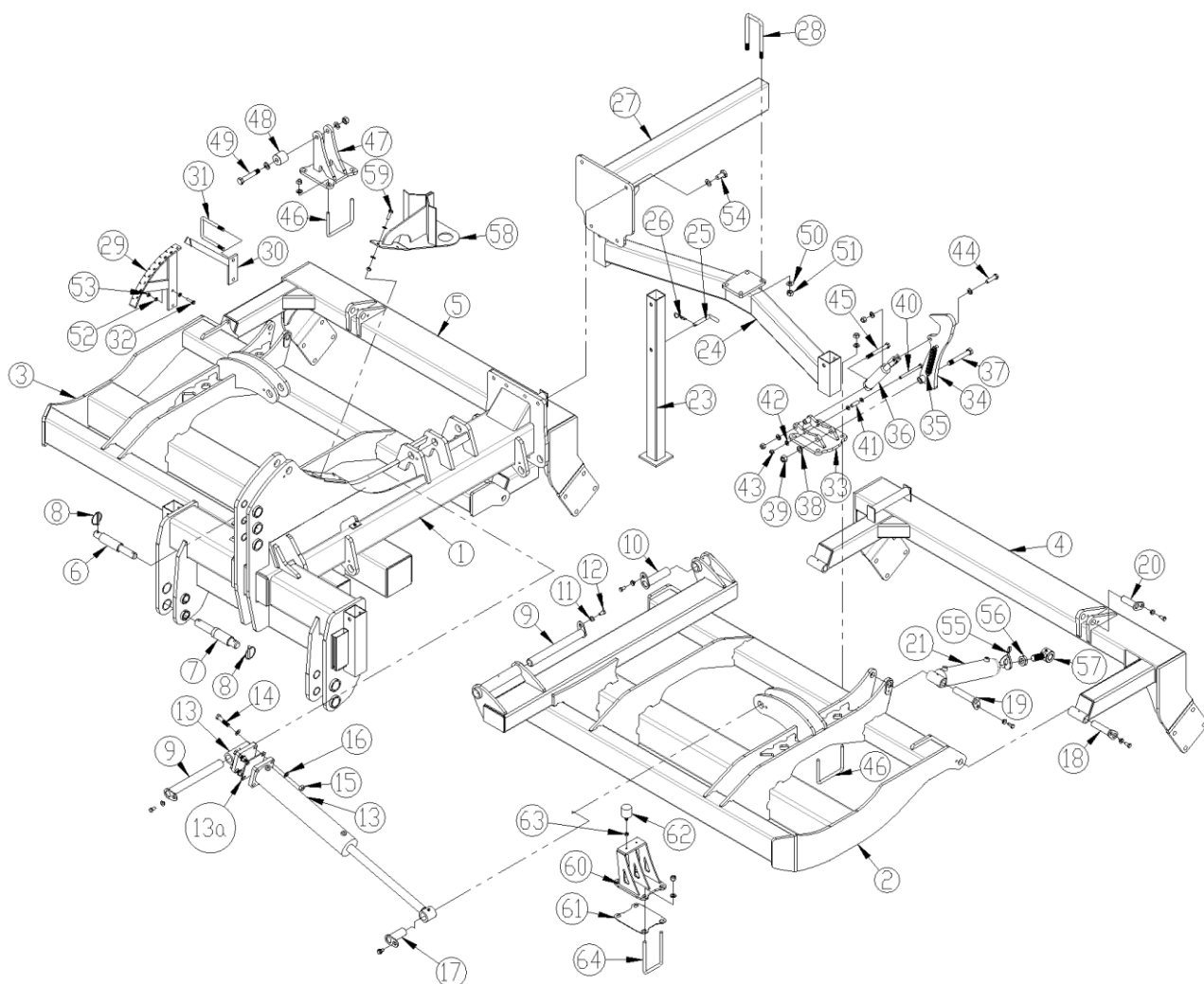

Pos.	Item no.	Designation	4,0m	5,0m	6,0m
1	1165076	Middle frame	1	1	1
	1165048	Wing (left)	1		
	1165134	Wing (left)		1	
	1165217	Wing (left)			1
3	1165052	Wing (right)	1		
	1165138	Wing (right)		1	
	1165221	Wing (right)			1
4	1165058	Roller bar (left)	1		
	1165158	Roller bar (left)		1	
	1165226	Roller bar (left)			1
5	1165056	Roller bar (right)	1		
	1165156	Roller bar (right)		1	
	1165228	Roller bar (right)			1
6	69532095C	Pin for top link Ø32/Ø44 L=95	1	1	1
7	69537125C	Pin for lift arm Ø37/Ø50x328	2	2	2
8	690134008	Ring pin, Ø11,5mm	3	3	3
9	69440367G	Pin Ø40 L=367	4	4	4
10	69440155G	Pin Ø40 L=155	2	2	2

Pos.	Item no.	Designation	4,0m	5,0m	6,0m
11	630532600	Lock bush for pin head	16	16	16
12	0235330	Bolt M12x25 8.8	16	16	16
13	690200255	Cylinder 90/40x500	2	2	
	690200273	Gasket set 690200255			
	1290079	Cylinder 110/50x500			2
	690200284	Gasket set 1290079			
13a	645000397	Shims 0,5mm (for 690200255)			
	645000396	Shims 1mm (for 690200255)			
	645200176	Shims 3mm (for 690200255)			
	645200178	Shims 4mm (for 690200255)			
	645000382	Shims 5mm (for 690200255)			
	7345130	Shims 0,5mm (for 1290079)			
	7345129	Shims 1mm (for 1290079)			
	7345128	Shims 3mm (for 1290079)			
14	0235860	Bolt M16x70 8.8	8	8	8
15	0264090	Locking nut M16			
16	0272290	Facet plate Ø16			
17	69440100G	Pin Ø40 L=100	2	2	2
18	69430145G	Pin Ø30 L=145	4	4	4
19	69430130G	Pin Ø30 L=130 (to march 2021)	2	2	2
	69430145G	Pin Ø30 L=145 (from march 2021)	2	2	2
20	69430095G	Pin Ø30 L=95	2	2	2
21	690200117	Cylinder (to and including 2020)	2	2	2
	7345106	Cylinder (from 2021)	2	2	2
	690200144	Gasket set for 690200117 and 7345106			
22	0432510	Lubricating nipple M8	2	2	2
23	1165403	Support leg	4	4	4
24	1165108	Support leg boom (back)	1	1	1
25	1030280	Pin Ø16 L=94	4	4	4
26	0377400	R-clip Ø4	4	4	4
27	1165078	Bracket for Support leg boom	1	1	1
28	690110405	U-bolt M18x160x80x160	2	2	2
29	645000162	Scale for depth control	1	1	1
30	645000165	Pointer for depth control	1	1	1
31	0382160	U-bolt M16x100x100x100	1	1	1
32	0235070	Bolt M10x40 8.8	2	2	2
33	630916606	Console f/Pawl	1	1	1
34	630916605	Pawl	1	1	1
35	0431651	Tension spring ø4x32x160mm x 30,5v	2	2	2
36	690200170	Cylinder 40/25x80mm	1	1	1
	690200175	Gasket set			
37	0236230	Bolt M20x140 8.8	1	1	1
38	0272310	Facet plate Ø20	12	12	12
39	0264110	Locking nut M20	6	6	6
40	0235500	Bolt M12x140 8.8	1	1	1
41	630916607	Tube Ø16 x 45mm	1	1	1
42	0272270	Facet plate Ø12	2	2	2
43	0264070	Locking nut M12	1	1	1

Pos.	Item no.	Designation	4,0m	5,0m	6,0m
44	0235840	Bolt M16x60 8.8	1	1	1
45	0235940	Bolt M16x140 8.8	1	1	1
46	0382800	U-bolt M16x100x150x100	4	4	4
47	1165101	Console f/Pawl	1	1	1
48	630670593	Roller Ø56 L=51	1	1	1
49	0236210	Bolt M20x120mm 8.8	1	1	1
50	0272300	Facet plate Ø18	4	4	4
51	0264100	Locking nut M18	4	4	4
52	0272260	Facet plate Ø10	4	4	4
53	0264060	Locking nut M10	2	2	2
54	0236090	Bolt M20x40 8.8	4	4	4
55	690200664	Distance clip blue 6,2mm	4	4	4
	690200665	Distance clip red 9,4mm	4	4	4
	690200666	Distance clip yellow 18.8mm	2	2	2
	690200667	Distance clip black 31.6mm	2	2	2
	690200668	Distance clip silver 50.8mm	2	2	2
56	0261452	Counter nut M30x2	1	1	1
57	690140772	Rod end (rigid) Ø30x45mm (M30x2mm male thread)	1	1	1
58	1165345	Support for accumulator	1	1	1
59	0235360	Bolt M12x40mm	3	3	3
60	1165333	Console (to December. 2020)	1	1	1
	1190848	Console (From January 2021)	1	1	1
61	1165352	Shims 3mm (to December. 2020)			
	1190851	Shims 3m (From January 2021)			
62	0484860	Rubber damper	2	2	2
63	0261360	Nut M10	2	2	2
64	690110104	U-bolt M16x150x100x150	2	2	2

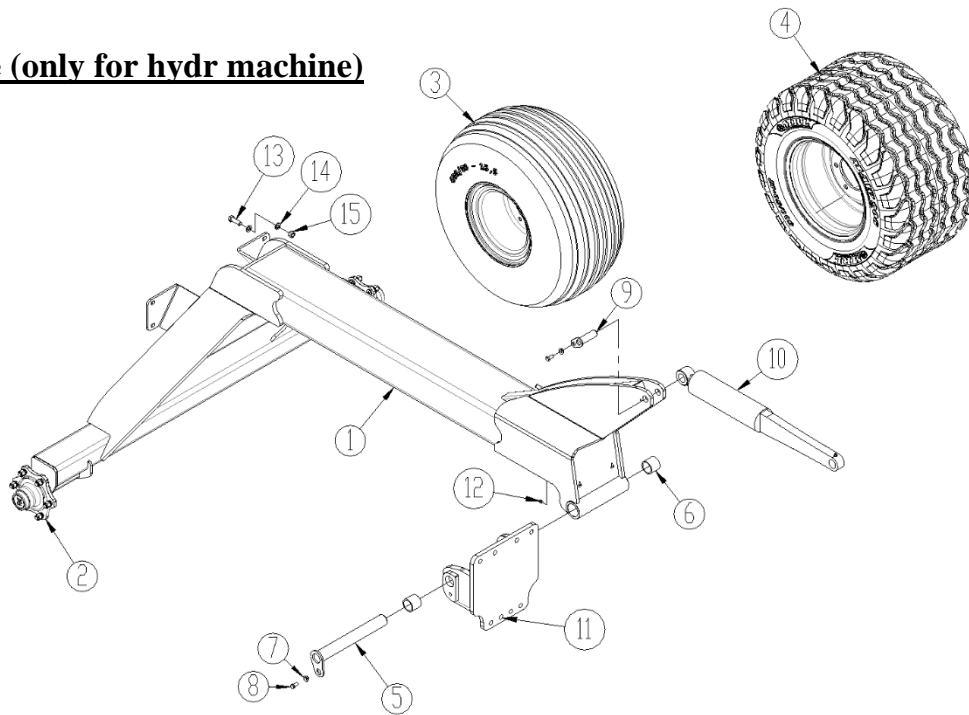
Wheel frame (only for hydr machine)

Pos.	Item no.	Designation	4,0m	5,0m	6,0m
1	1141258	Wheel support, 2500 kg hub (check target 1738mm)	1	1	1
	1141262	Wheel support w/brakes, 2500 kg hub (check target 1738mm)			
2	690141030	Hub 2500 kg			
	0396420	Sealing ring			
	690140105	Bearing 30208			
	690140111	Bearing 30211			
	0396470	Hub nut			
	0396460	Hub bolt			
	690141033	Hub cap			
	0396480	Castellated nut			
3	0396300	Wheel (complete) 400/60 15,5 14 Ply (discontinued)	2	2	
4	0396650	Wheel (complete) 500/50 17 14 Ply	2	2	2
5	69450400G	Pin Ø50 L=400	1	1	1
6	0475400	Inner tension bush EG Ø60/50 L= 50mm	2	2	2
7	630532600	Lock bush for pin head	2	2	2
8	0235330	Bolt M12x25mm	2	2	2
9	69440090G	Pin Ø40 L= 90	1	1	1
10	7345138	Cylinder	1	1	1
	0463370	Gasket set			
11	1165089	Bracket	1	1	1
12	0432510	Lubricating nipple M8			
13	0235810	Bolt M16x50	4	4	4
14	0272290	Facet plate Ø16	8	8	8
15	0264090	Locking nut M16	4	4	4

Rollers

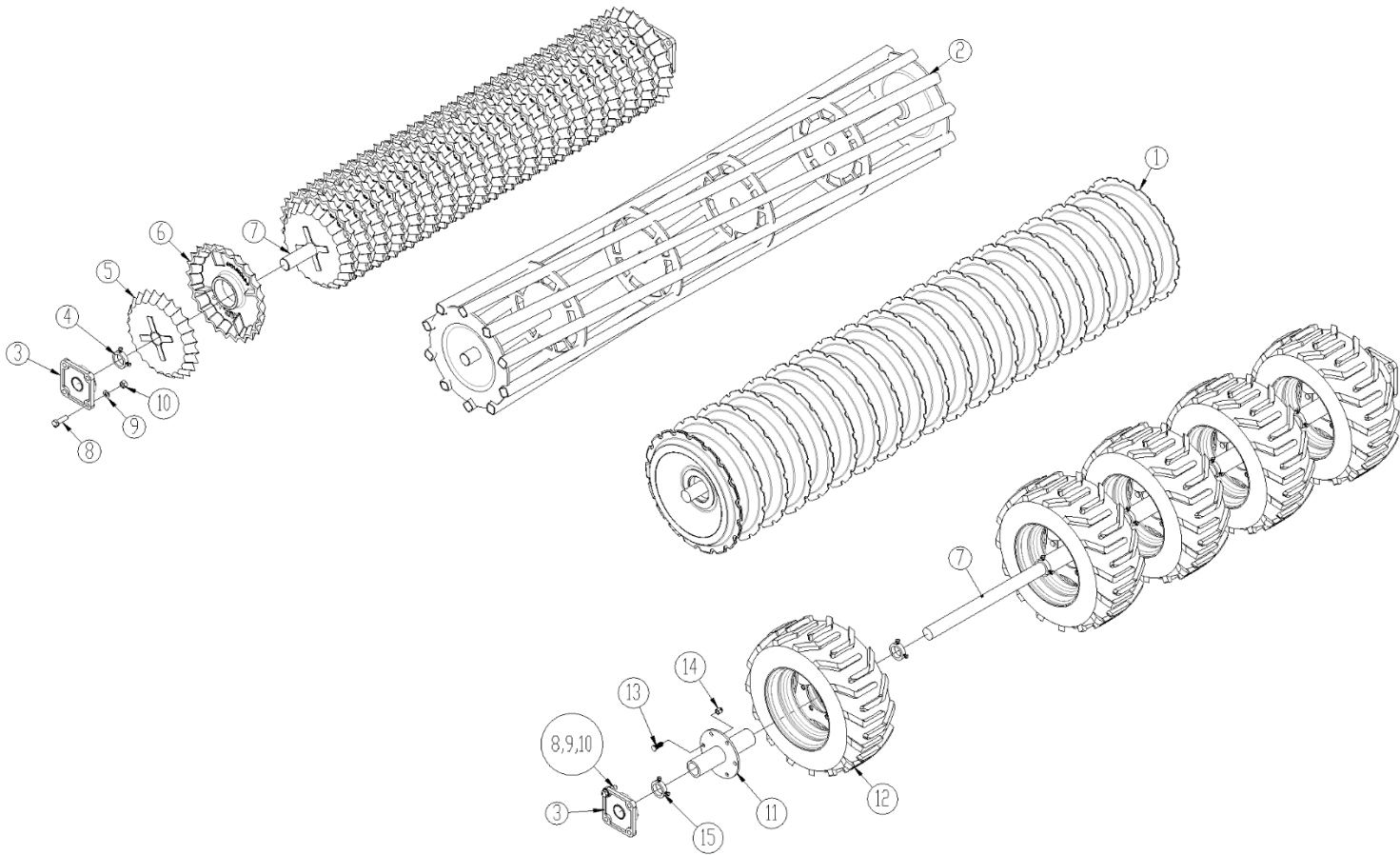

Pos	Item no.	Designation	3m	3,5m	4m rigid	4m hydr	5m	6m
1	1160470	V-profil roller	1					
	1160480	V-profil roller		1				
	1160481	V-profil roller			1			
	7451166	V-profil roller (right)				1		
	7451172	V-profil roller (left)				1		
	7451161	V-profil roller (right)					1	
	7451158	V-profil roller (left)					1	
	7451184	V-profil roller (right)						1
	7451181	V-profil roller (left)						1
2	1048240	Square tube roller Ø550	1					
	1048280	Square tube roller Ø550		1				
	1048330	Square tube roller Ø550			1			
	xxxx	Square tube roller Ø550 (right)				1		
	xxxx	Square tube roller Ø550 (left)				1		
	xxxx	Square tube roller Ø550 (right)					1	
	xxxx	Square tube roller Ø550 (left)					1	
3	0478971	Bearing complete Ø60 UCF 312	2	2	2	4	4	4
4	671040400	Stop ring	2	2	2	4	4	4
5	690150064	Star rings Ø450	24	29	34	28	39	49

Pos	Item no.	Designation	3m	3,5m	4m rigid	4m hydr	5m	6m
6	690150063	Star rings Ø500	24	29	34	28	39	49
7	678672935	Axle 2935mm	1					
	678613435	Axle 3435mm		1				
	678613935	Axle 3935mm			1			
	7451168	Axle 1800mm				1		
	7451174	Axle 2055mm				1		
	7451162	Axle 2308mm					1	
	7451159	Axle 2565mm					1	
	xxx	Axle 2808mm						1
	xxx	Axle 3065mm						1
8	0236140	Bolt M20x65mm	8	8	8	16	16	16
9	0272310	Facet plate M20	16	16	16	32	32	32
10	0264110	Locking nut M20	8	8	8	16	16	16

Pos	Item no..	Designation	Number per leg
11	7365037	Hub, 6 bolt, Ø60	1
12	0395653	Wheel 300/55-14.5 SG Flotation right	1
	0395654	Wheel 300/55-14.5 SG Flotation left	
13	0396460	Hub bolt M18 x 1.5 L=49mm	6
14	0396470	Hub nut M18 x 1.5	6
15	671040400	Stop ring	2

Scraper

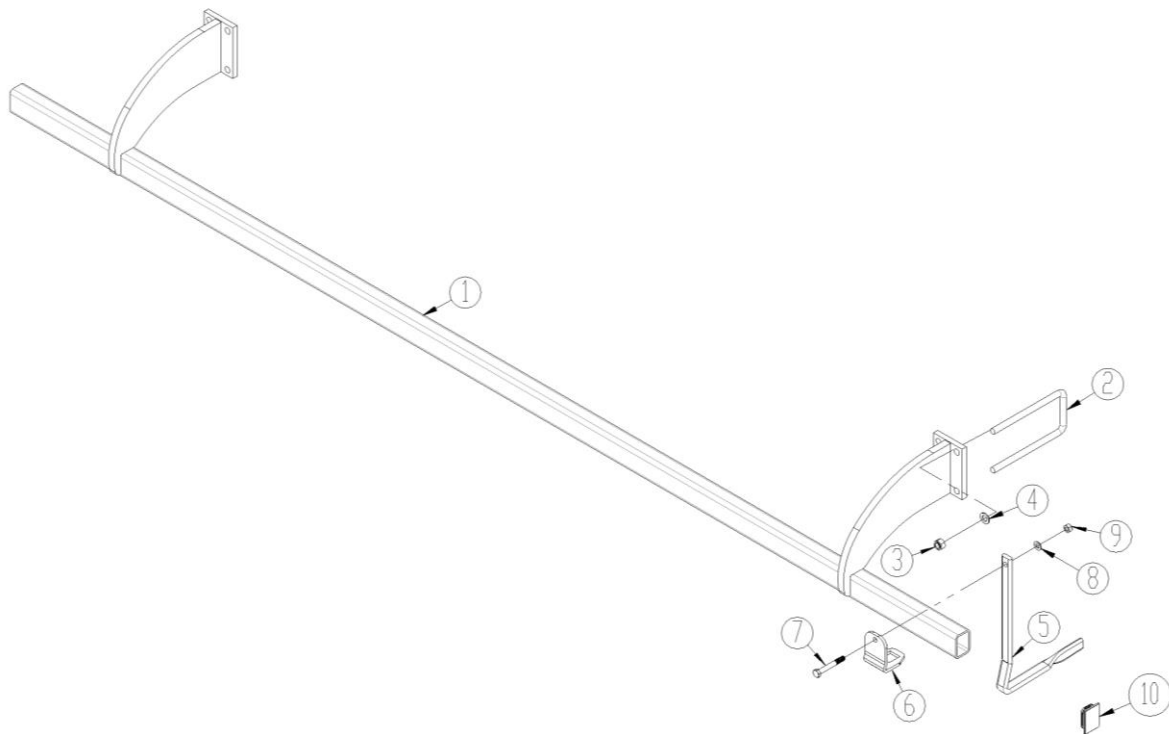

Pos	Item no.	Designation	3m	3,5m	4m rigid	4m hydr	5m	6m
1	645000799	Scraper bar	1					
	645000827	Scraper bar		1				
	645000823	Scraper bar			1			
	1165066	Scraper bar (right)				1		
	1165061	Scraper bar (left)				1		
	1165162	Scraper bar (right)					1	
	1165160	Scraper bar (left)					1	
	1165243	Scraper bar (right)						1
	1165241	Scraper bar (left)						1
2	690110106	U-bolt M16x200x100x200	4	4	4	8	8	8
3	0264090	Locking nut M16	8	8	8	16	16	16
4	0272290	Facet plate Ø16	8	8	8	16	16	16
5	630938520	Scraper, short 255mm	19	22	26	22	30	36
6	630938522	Clamp f/scraper	19	22	26	22	30	36
7	0235450	Bolt M12x90mm.	19	22	26	22	30	36
8	0272270	Facet plate Ø12	38	44	52	44	60	72
9	0264070	Locking nut M12	19	22	26	22	30	36
10	0489487	Plastic pipe plug	2	2	2	4	4	4

Easy Draft tine w/Quick-Push shear bolt

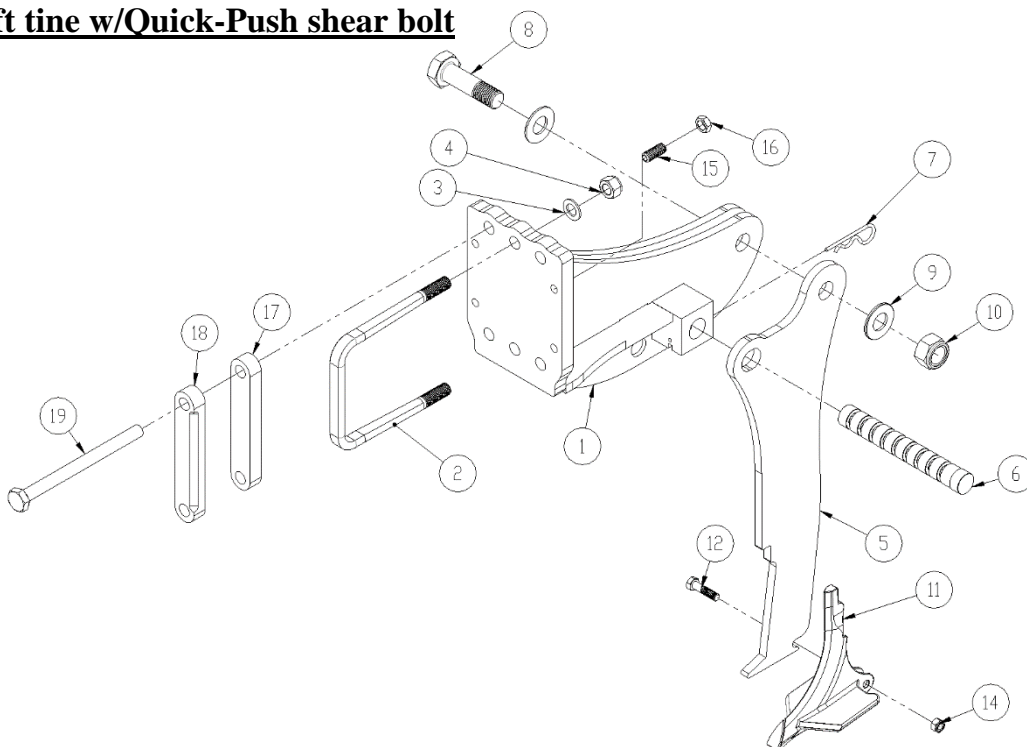

Pos	Item no.	Designation	Number per leg
1	1165021	Tine bracket (short model)	
	1165027	Tine bracket (long model)	
	1165257	Tine bracket (short model) (tine spacing 75cm)	
	1165259	Tine bracket (long model) (tine spacing 75cm)	
2	690110500	U-bolt M20x180x180x180mm (until machine nr 38230)	3
	690110500	U-bolt M20x180x180x180mm (from machine nr 38231)	1
3	0272310	Facet plate Ø20	6
4	0264110	Locking nut M20	6
5	1165026	Tine	1
	1165570	Tine w/1 hardmetal	
6	645000925	Shear bolt ø35 (chrome black)	1
7	0377600	R-clip 6mm	1
8	690103868	Bolt M30x95 10.9	1
9	0272350	Facet plate Ø30	2
10	0264155	Locking nut M30	1
11	645000056	Points w/hardmetal (center)120mm	1
	645000056T	Points w/hardmetal (center/wing)120mm	
	645000054	Points w/hardmetal (center) 200mm	
	645000054T	Points w/hardmetal (center/wing) 200mm	
12	0235372	Bolt M12x50 (special bolt)	1
14	0264070	Locking nut M12	1
15	0227528	Stop screw M16x40	6
16	0261392	Lock-nut M16	6
17	1245080	Flange (from machine nr 38231)	2
18	645410052	Flange (45° chamfer) (from machine nr 38231)	0
19	0236313	Bolt M20x260 (from machine nr 38231)	4

Easy Draft tand m/hydr. automatudløsning

To Machine no 38017

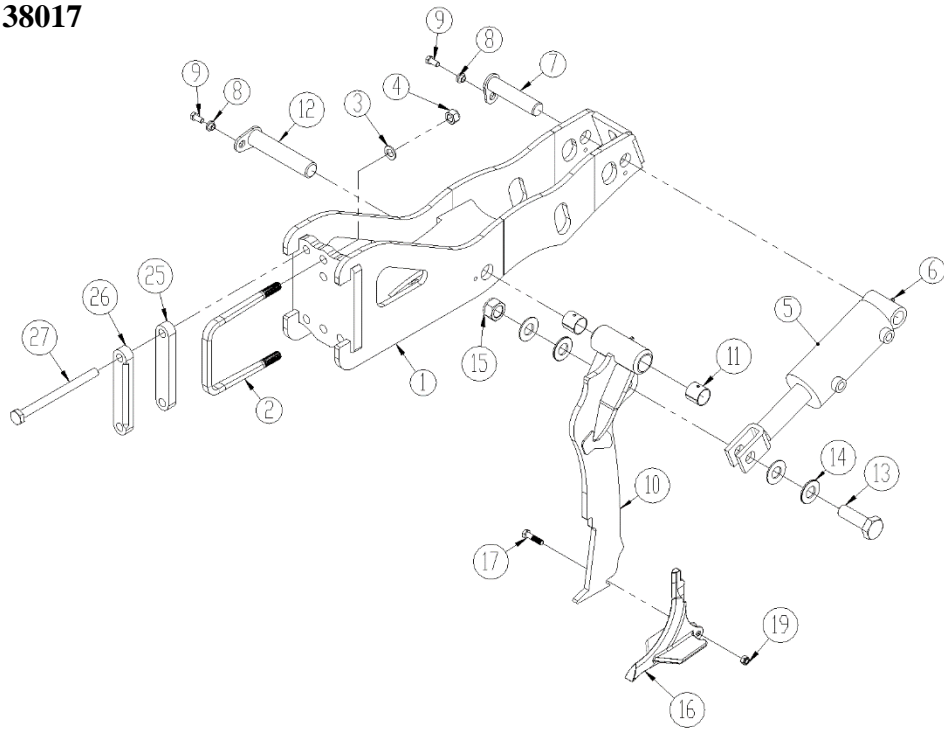

From Machine no 38018

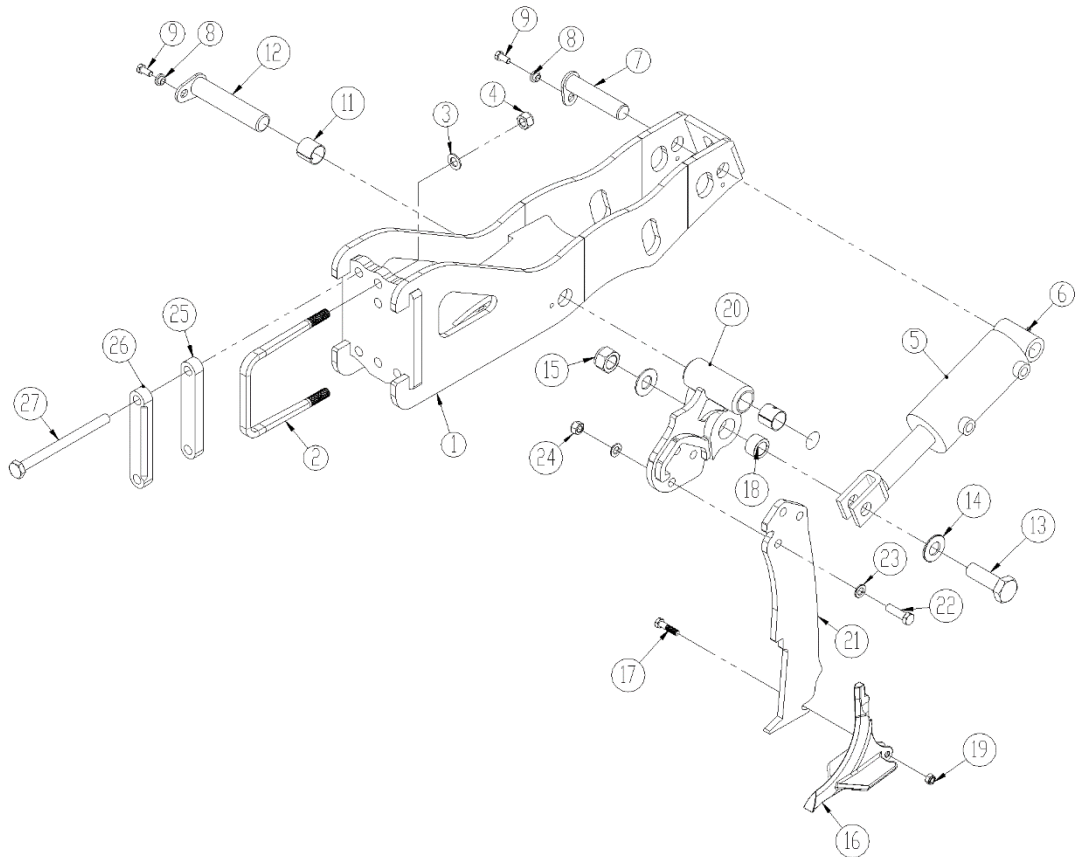

Pos	Item no.	Designation	Antal pr. ben
1	1165000	Tine bracket (short model)	
	1165011	Tine bracket (long model)	
2	690110500	U-bolt M20x180x180x180mm (until machine nr 38230)	3
	690110500	U-bolt M20x180x180x180mm (from machine nr 38231)	1
3	0272310	Facet plate Ø20	6
4	0264110	Locking nut M20	6
5	690200114	Cylinder 100/50x130 Ø35/Ø30	1
	690200285	Gasket set	
6	0432510	Lubricating nipple M8	2
7	69435155G	Pin Ø35 L=155	1
8	630532600	Lock bush for pin head	2
9	0235330	Bolt M12x25 8.8	2
10	1165007	Tine	1
	1165577	Tine w/1 hardmetal	
11	0475100	Slide bush Ø40/Ø44 L=40 (until April 2024)	2
	0475309	Inner tension bush EG ø44/40x40mm (from May 2024)	
12	69440195G	Pin Ø40 L=195	1
13	690103868	Bolt M30x95 10.9	1
14	0272350	Facet plate Ø30	4
15	0264155	Locking nut M30	1
16	645000056	Points w/hardmetal (center)120mm	1
	645000056T	Points w/hardmetal (center/wing)120mm	
	645000054	Points w/hardmetal (center) 200mm	
	645000054T	Points w/hardmetal (center/wing) 200mm	
17	0235372	Bolt M12x50 (special bolt)	1
18	645000113	Bushing Ø30/Ø45	1
19	0264070	Locking nut M12	1
20	1165559 ♦	Bracket t/M16 bolte (until spring 2024)	1
	1165559 ♦	Bracket t/M18 bolte (from spring 2024)	1
21	1165564 ♦	Tine t/M16 bolte (until spring 2024)	1
	1165564 ♦	Tine t/M18 bolte (from spring 2024)	1
	1165622 ♦	Tine w/1 hardmetalplate t/M16 bolt (until spring 2024)	1
	1165622 ♦	Tine w/1 hardmetalplate t/M18 bolt (from spring 2024)	1
22	0235830 ♦	Bolt M16x55 8.8 (until 16/8 2023)	3
	0235831 ♦	Bolt M16x55 (from 17/8 2023 until spring 2024)	3
	0236045 ♦	Bolt M18x60 10.9 (from spring 2024)	3
23	0272290 ♦	Facet plate Ø16 (until spring 2024)	6
	0272300 ♦	Facet plate Ø18 (from spring 2024)	6
24	0264090 ♦	Locking nut M16 (until spring 2024)	3
	0264100 ♦	Locking nut M18 (from spring 2024)	3
25	1245080	Flange (from machine nr 38231)	2
26	645410052	Flange (45° chamfer) (from machine nr 38231)	0
27	0236313	Bolt M20x260 (from machine nr 38231)	4

♦ **ATTENTION:** When re-ordering items 20-24, check the hole size in both tine and bracket, so that the correct bolt, nut and facet plate are send with.

Disc-opens (rigid)

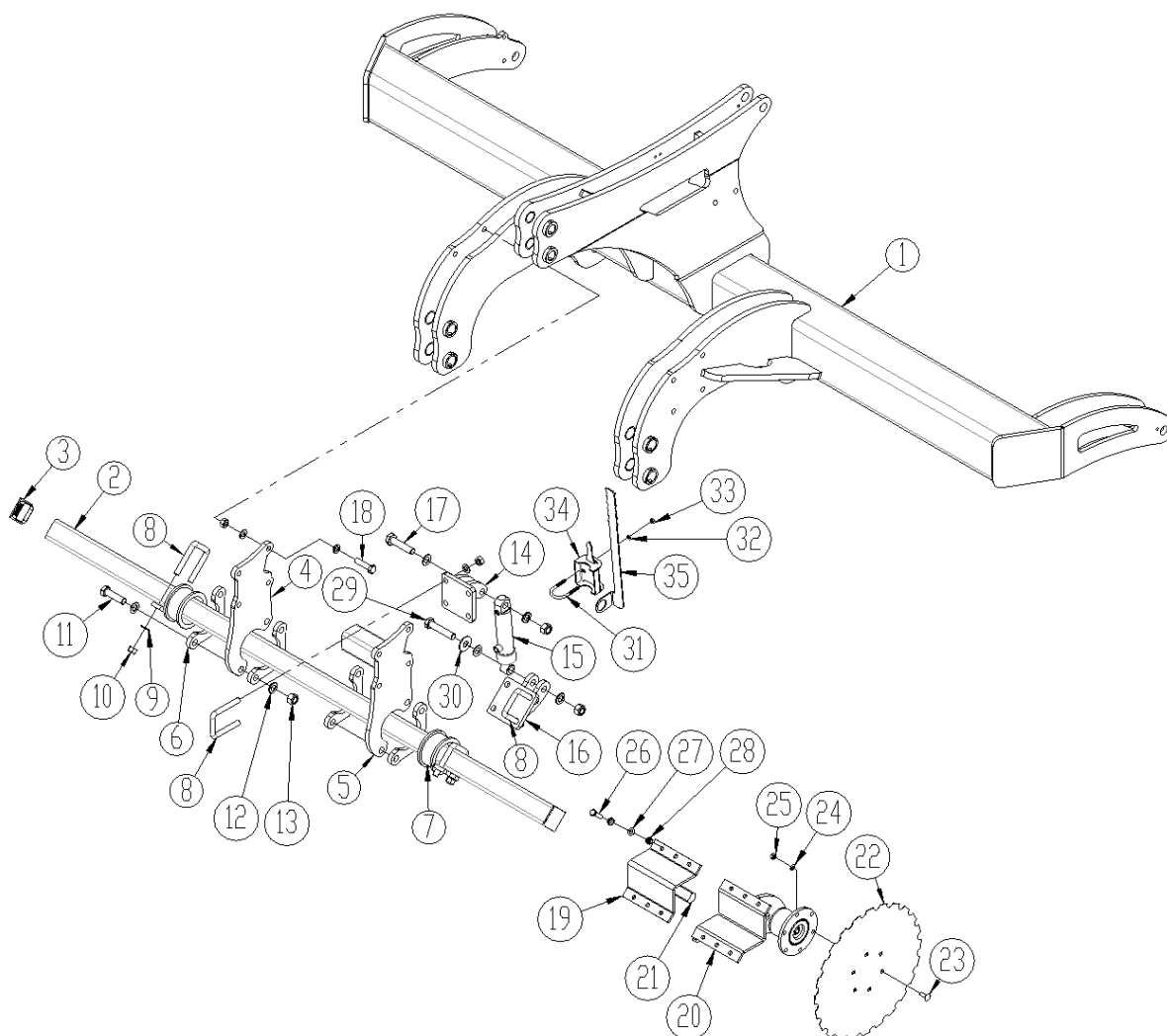

Pos.	Item no.	Designation	3,0m	3,5m	4,0m
1		Look at pos 1 page 20			
2	1165398	Bar	1		
	1165399	Bar		1	
	1165362	Bar			1
3	690109202	Plastic pipe plug	2	2	2
4	1165174	Bracket f/bar (to 31/12 2021)			
	1165592	Bracket f/bar (from 1/1 2022)			
5	1165199	Bracket for bar/cylinder (right) (to 31/12 2021)			
	1165198	Bracket for bar/cylinder (left) (to 31/12 2021)			
	1165603	Bracket for bar/cylinder (right) (from 1/1 2022)			
	1165591	Bracket for bar/cylinder (left) (from 1/1 2022)			
6	1170499	Locking device	4	4	4
7	1165148	Bushing	2	2	2
8	0382150	U-bolt M16x70x70x70 (until 30/9 2024)	6	6	6
	0382150	U-bolt M16x70x70x70 (from 1/10 2024)	6	10	10
9	0272290	Facet plate Ø16 (until 30/9 2024)	28	28	28
	0272290	Facet plate Ø16 (from 1/10 2024)	28	36	36

Pos.	Item no.	Designation	3,0m	3,5m	4,0m
10	0264090	Locking nut M16 (until 30/9 2024)	20	20	20
	0264090	Locking nut M16 (from 1/10 2024)	20	28	28
11	0236160	Bolt M20x75 8.8	4	4	4
12	0272310	Facet plate Ø20 (until 30/9 2024)	12	12	12
	0272310	Facet plate Ø20 (from 1/10 2024)	12	16	16
13	0264110	Locking nut M20 (until 30/9 2024)	6	6	6
	0264110	Locking nut M20 (from 1/10 2024)	6	8	8
14	1165176	Bracket f/cylinder (to 31/12 2021)	1	1	1
	1165593	Bracket f/cylinder (from 1/1 2022 to 30/9 2024)	1	1	1
	1165593	Bracket f/cylinder (from 1/10 2024)	1	2	2
15	0468200	Cylinder 40/20 x99mm 2x1/4" (until 30/9 2024)	1	1	1
	0468200	Cylinder 40/20 x99mm 2x1/4" (from 1/10 2024)	1	2	2
	0468270	Gasket set			
16	1165183	Bracket f/cylinder (to 31/12 2021)	1	1	1
	1165596	Bracket f/cylinder (from 1/1 2022 to 30/9 2024)	1	1	1
	1165596	Bracket f/cylinder (from 1/10 2024)	1	2	2
17	0236180	Bolt M20x90 8.8 (until 30/9 2024)	1	1	1
	0236180	Bolt M20x90 8.8 (from 1/10 2024)	1	3	3
18	690103275	Bolt M16x65 10.9	8	8	8

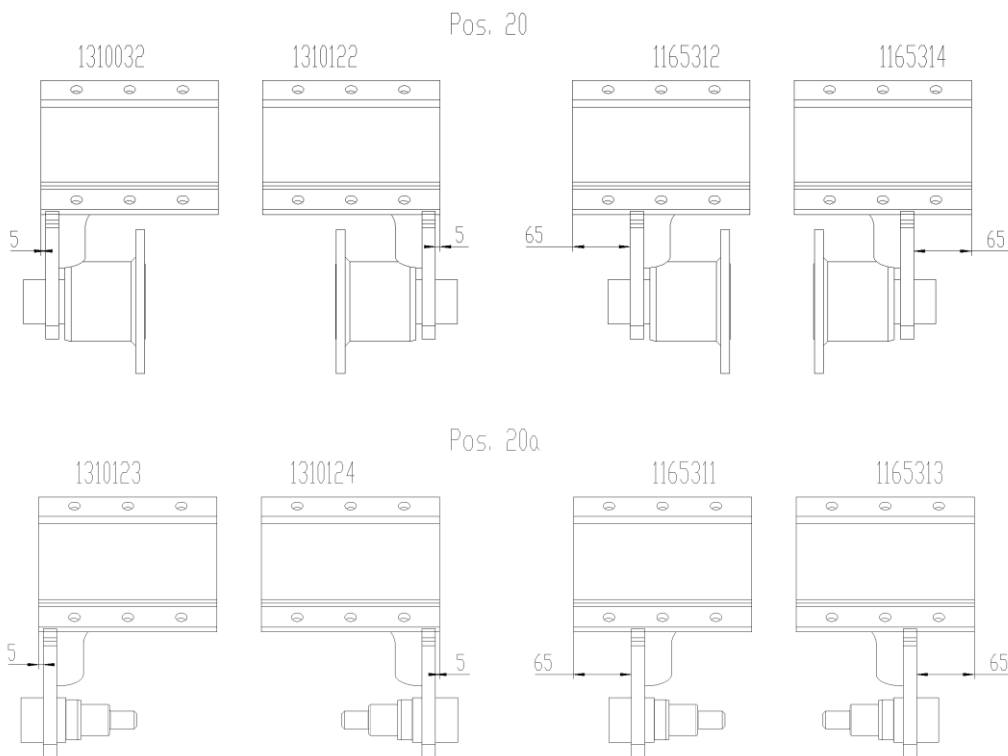

Pos.	Item no.	Designation	Number per leg
19	30949045	Bracket	1
20	1310032	Carrier arm w/hub (right)	1
	1165020	Complete Carrier arm w/Disc (right) (pos 19-28)	
	1310122	Carrier arm w/hub (left)	1
	1165268	Complete Carrier arm w/Disc (left) (pos 19-28)	

Pos.	Item no.	Designation	Number per leg
	1165312	Carrier arm w/hub (right)	1
	1165318	Complete Carrier arm w/Disc (right) (pos 19-28)	
	1165314	Carrier arm w/hub (left)	1
	1165319	Complete Carrier arm w/Disc (left) (pos 19-28)	
20a	1310123	Carrier arm (right)	
	1310124	Carrier arm (left)	
	1165311	Carrier arm (right)	
	1165313	Carrier arm (left)	
		To 31/5 2023	
20b	630949019	Steel washer (offset) Ø45/71,7 mm	
20c	690140651	Sealing cassette 72-45-14/17	
20d	690140201	Bearing (Taper roller bearing) ø72mm x ø35mm x 33	
20e	0379250	Seeger circlip ring I 72 DIN472	
20f	30949030	Hub	
20g	690140652	Tight-fitting washer Ø40/50x1mm (Din 988)	
20h	0483738	O-ring 84,5 x 3	
20i	690117063	Disc spring 20,4x45x2,5	
20j	0263000	Locking nut M20 kv. 10 (all metal)	
20k	630949035	Reparation set	
		From 1/6 2023	
20b	630949019	Steel washer (offset) Ø45/71,7 mm	
20c	690140651	Sealing cassette 72-45-14/17	
20d	690140199	Taper roller bearing JMR3565XD	
20e	0379253	Seeger circlip ring I 72 DIN 984	
20f	30949032	Hub	
20h	0483738	O-ring 84,5 x 3	
20i	690117062	Washer 5mm (ø20)	
20j	0263000	Locking nut M20 kv. 10 (all metal)	
20k	630949032	Reparation set	
21	690210710	Rubber cord Ø35 L=190 mm	4
22	0427854	Disc Ø470mm	1
23	0248421	Carriage bolt M10x30	6
24	0272260	Facet plate Ø10	6
25	0264060	Locking nut M10	6
26	690103091	Bolt M12x45 10.9	6
27	0272270	Facet plate Ø12	12
28	0264070	Locking nut M12	6

Pos.	Item no.	Designation	3,0m	3,5m	4,0m
29	0236190	Bolt M20x100 8.8 (from Jan 2021)	1	1	1

Pos.	Item no.	Designation	3,0m	3,5m	4,0m
30	1165377	Plate (from Jan 2021)	1	1	1
31	0384200	U-bolt Ø50/M8 (from Jan 2021)	1	1	1
32	0272250	Facet plate Ø8 (from Jan 2021)	2	2	2
33	0264050	Locking nut M8 (from Jan 2021)	2	2	2
34	1165370	Scale for depth control (from Jan 2021)	1	1	1
35	1165369	Pointer for depth control (from Jan 2021)	1	1	1

Disc-opens 4m - 6m (hydr)

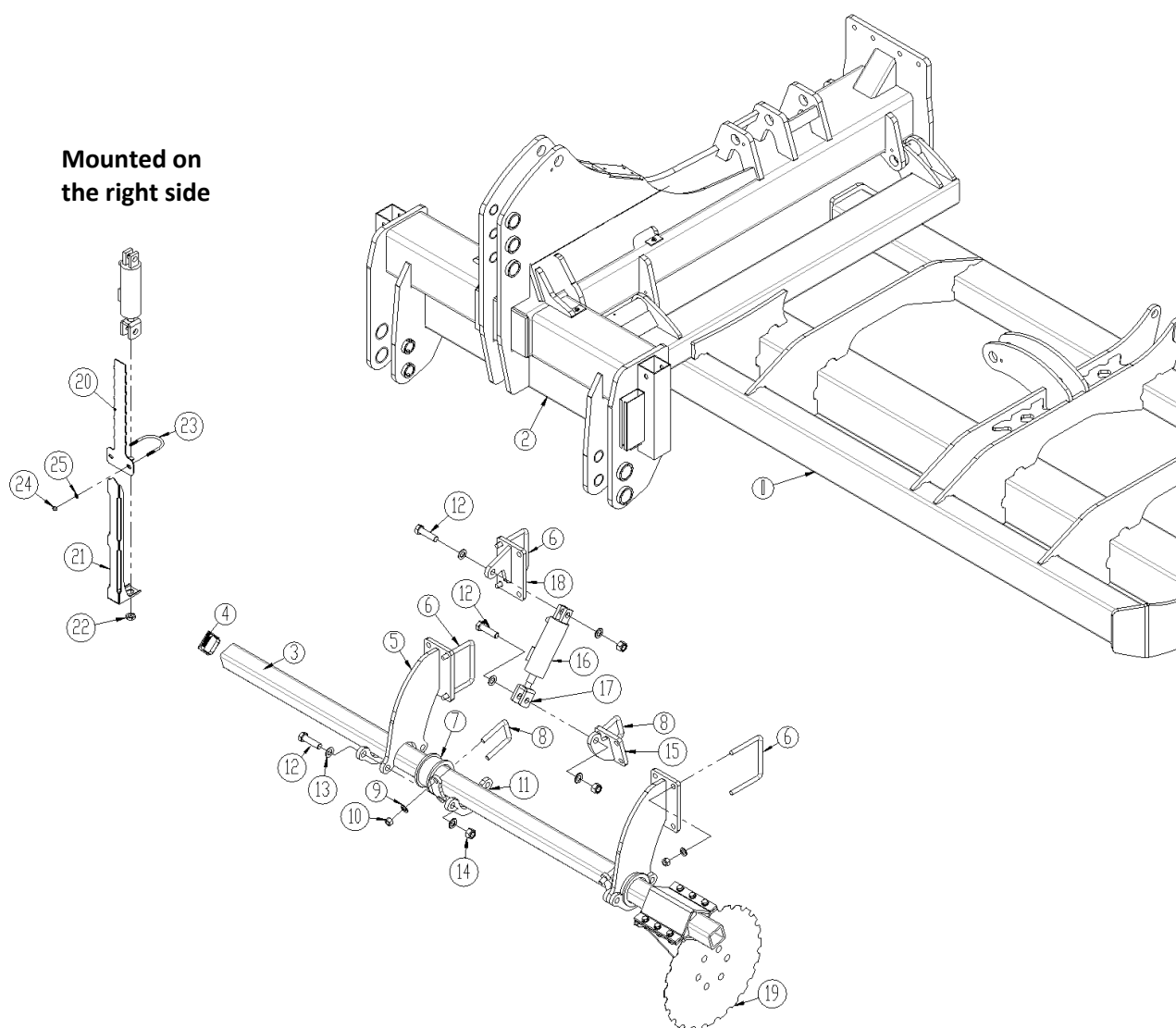

Pos.	Item no.	Designation	4,0m	5,0m	6,0m
1		Look at pos. 2 and 3 page 22			
2		Look at pos. 1 page 22			
3	1165070	Bar (left)	1		
	1165071	Bar (right)	1		
	1165169	Bar (left)		1	
	1165170	Bar (right)		1	
	1165239	Bar (left)			1
	1165240	Bar (right)			1
4	690109202	Plastic pipe plug	4	4	4
5	1165142	Bracket f/bar (to 31/12 2021)	4	4	4
	1165574	Bracket f/bar (from 1/1 2022)	4	4	4
6	0382800	U-bolt M16x100x150x100	12	12	16
7	1165148	Bushing	2	2	2
8	0382150	U-bolt M16x70x70x70	8	8	12
9	0272290	Facet plate Ø16	40	40	40
10	0264090	Locking nut M16	40	40	40

Pos.	Item no.	Designation	4,0m	5,0m	6,0m
11	1170499	Locking device	8	8	8
12	0236160	Bolt M20x75 8.8	12	12	12
13	0272310	Facet plate Ø20	24	24	24
14	0264110	Locking nut M20	12	12	12
15	1165044	Bracket (cylinder) (to 31/12 2021)	2	2	4
	1165586	Bracket (cylinder) (from 1/1 2022)	2	2	4
16	7345118	Cylinder 75/65x25 ..99 (left)	1	1	2
	7345111	Cylinder 70/60x25 ..99 (right)	1	1	2
	0469070	Gasket set 7445118			
	0468970	Gasket set 7445111			
17	1114090	Fork f/cylinder	2	2	4
18	1165147	Bracket (wing) (til 31/12 2021)	2	2	4
	1165584	Bracket (wing) (fra 1/1 2022)	2	2	4
19		Look at pos. 19-28 page 32			
20	1165356	Scale for depth control (from Jan 2021)	1	1	1
21	1165364	Pointer for depth control (from Jan 2021)	1	1	1
22	0261411	Nut M20 (from Jan 2021)	1	1	1
23	690110113	U-bolt Ø75/M8 (from Jan 2021)	1	1	1
24	0264050	Locking nut M8 (from Jan 2021)	2	2	2
25	0272250	Facet plate Ø8 (from Jan 2021)	2	2	2

Plateau (rigid)

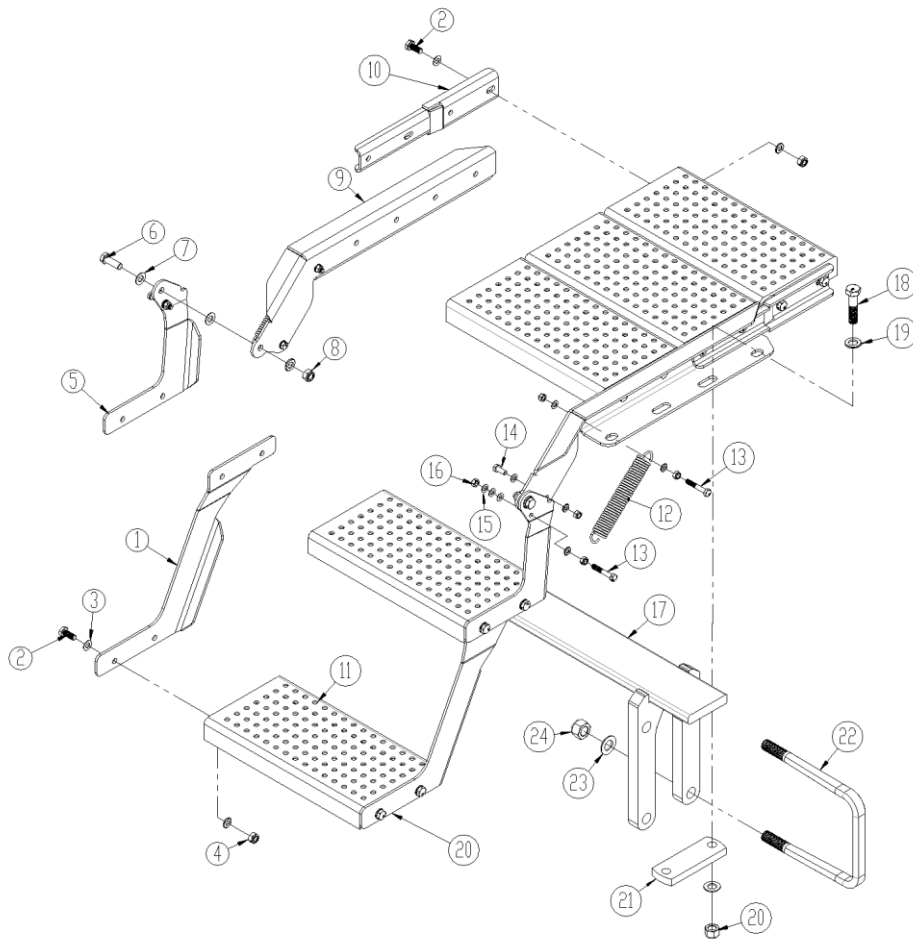

Pos.	Item no.	Designation	No.
1	1335251	String (L)	1
	1335252	String (R)	1
2	0235040	Bolt M10x25mm	20
3	0272260	Facet plate Ø10	40
4	0264060	Locking nut M10	20
5	1335074	String (L)	1
	1335073	String (R)	1
6	0235350	Bolt M12x35mm	2
7	0272270	Facet plate Ø12	6
8	0264070	Locking nut M12	2
9	1190745	String	1
	1190746	String	1
10	1190751	String	2
11	0487007	Stair tread	5
12	0431651	Tension spring ø4x32x160mm x 30,5v	2
13	0234810	Bolt M8x50mm	4
14	0234750	Bolt M8x20mm	2
15	0272250	Facet plate Ø8	16
16	0264050	Locking nut M8	6
17	1191028	Bracket	1
18	0235850	Bolt M16x65mm	4
19	0272290	Facet plate Ø16	8
20	0264090	Locking nut M16	4
21	1076140	Bracket	2
22	690110500	U-bolt M20x180x180x180 mm	2
23	0272310	Facet plate Ø20	4
24	0264110	Locking nut M20	4

Plateau (hydraulic)

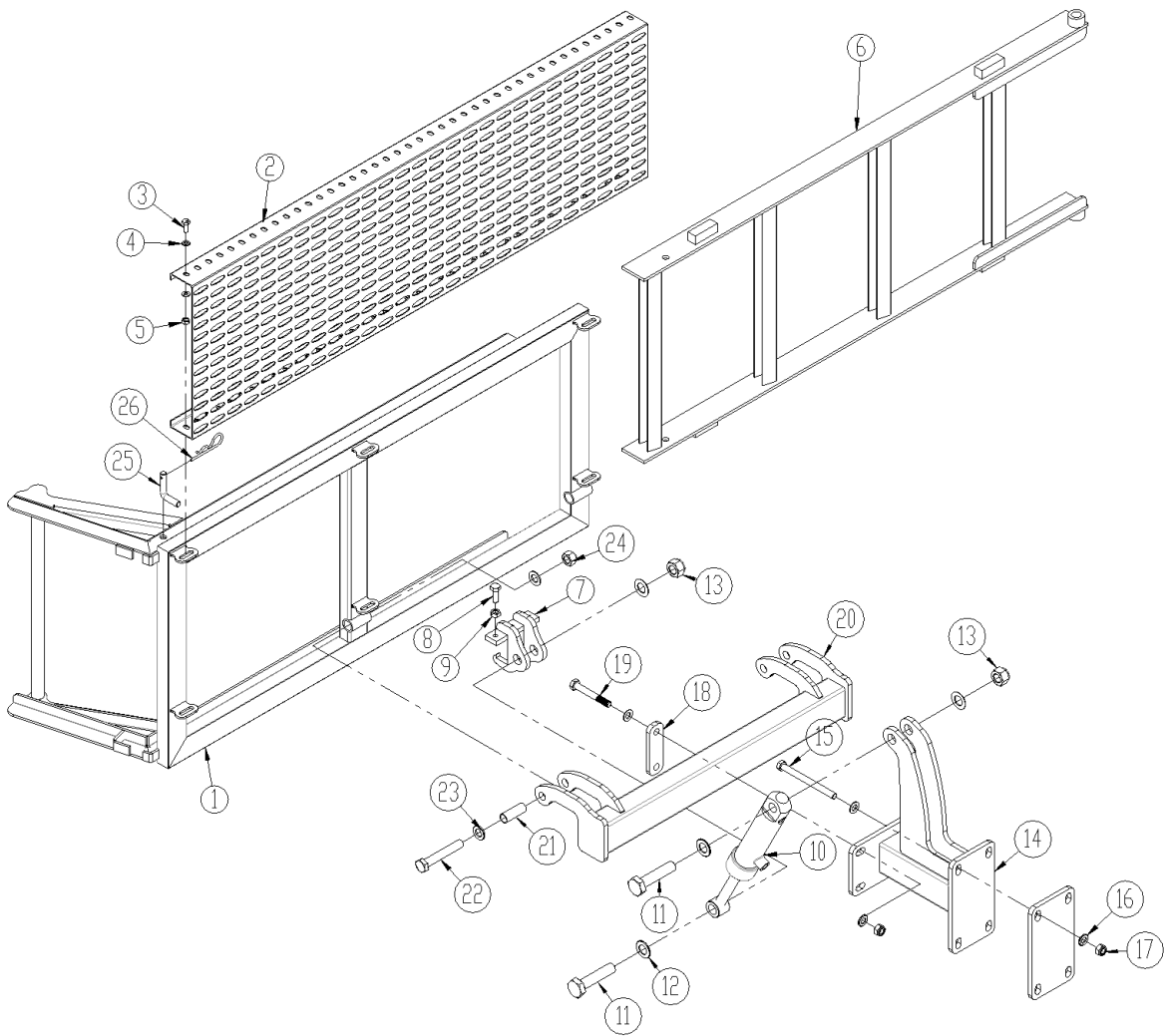

Pos.	Item no.	Designation	No.
1	1139924	Bracket for Platform	1
2	0487060	Platform	1
3	0234750	Bolt M8x20 mm	6
4	0272250	Facet plate Ø8	12
5	0264050	Locking nut M8	6
6	1132870	Ladder	1
7	1139922	Cylinder bracket	1
8	0235050	Bolt M10x30 mm	3
9	0261363	Counter nut M10	3
10	0468200	Cylinder 40/20 x 99mm 2 x 1/4"	1
11	0236180	Bolt M20x90 mm	2
12	0271580	Facet plate Ø20	4
13	0264110	Locking nut M20	5
14	1139910	Consol	1
15	0235500	Bolt M12x140mm	4
16	0272270	Facet plate Ø12	16
17	0264070	Locking nut M12	8
18	1139925	Clamping plate	2
19	0235450	Bolt M12x90mm	4
20	1139921	Consol	1
21	1139913	Bushing	2
22	0235900	Bolt M16x100 mm	2
23	0272290	Facet plate Ø16	4
24	0264090	Locking nut M16	2
25	1100490	Pin Ø12	1
26	0377400	R-clip Ø4	1

LED-Light

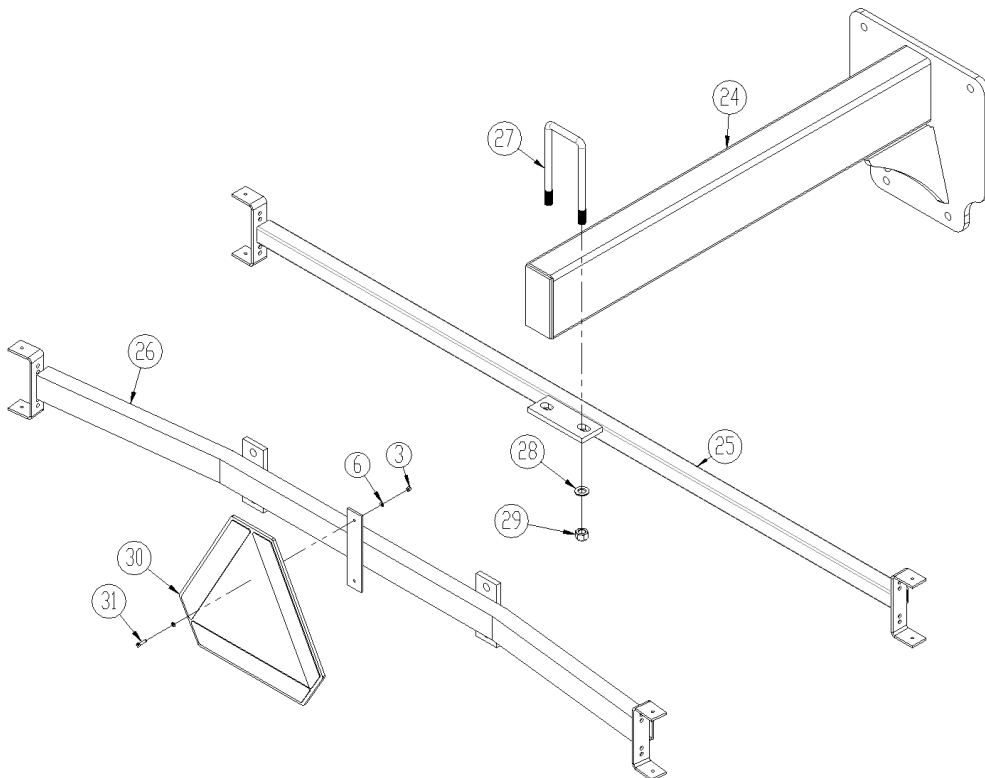
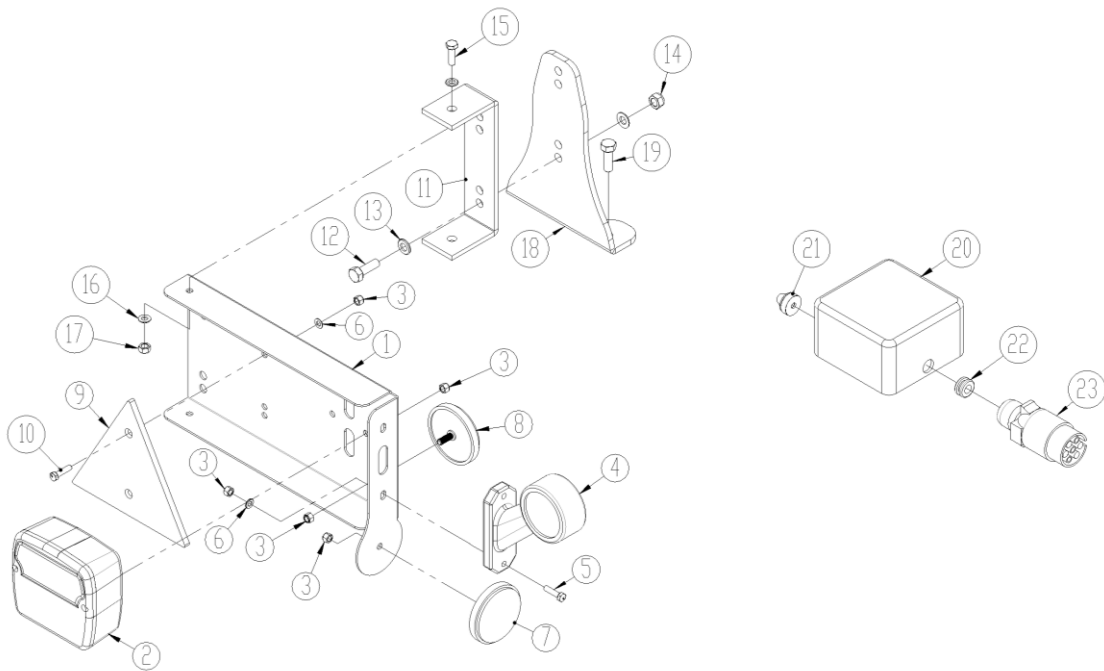

Pos.	Item no.	Designation	No.
1	7357505	Light bracket, left	1
	7357508	Light bracket, right	1
2	7357504	Rear light	2
3	0264030	Self-locking nut M5	
4	7357507	Marking lights (left)	1
	7357509	Marking lights (right)	1
5	0233860	Bolt M5x20	
6	0272230	Facet plate Ø5	
7	0656240	Reflex, yellow	2
8	0656250	Reflex, white	2
9	0521030	Reflex, red	2
10	0233860	Bolt M5x20	
11	7357516	Bracket	2
12	0234760	Bolt M8x25	
13	0272250	Facet plate Ø8	
14	0264050	Locking nut M8	
15	0234330	Bolt M6x20	
16	0272240	Facet plate Ø6	
17	0264040	Locking nut M6	
18	30910110	Consol	2
19	0230825	Taptite bolt M8x25	
20	0520492	Connecting box 105x105x60	1
21	7357545	Rutaseal nippel M20 8-12mm	2
22	7357546	Rubber bushing	1
23	0527140	Plug 7 poles DIN 72 577 – ISO 1724	1
	690160080	Cable 5x1mm ²	
24		See pos 27 page 22	
25	645000360	Bar for light (hydr)	
26	630835015	Bar for light (trailed)	
27	690110107	U-bolt M16x80x80x80mm	1
28	0272290	Facet plate 16mm	2
29	0264090	Locking nut M16	2
30	0521010	Advarselstrekant	1
31	0233860	Bolt M5x20	

Hydraulics

Drawbar and Wheel frame

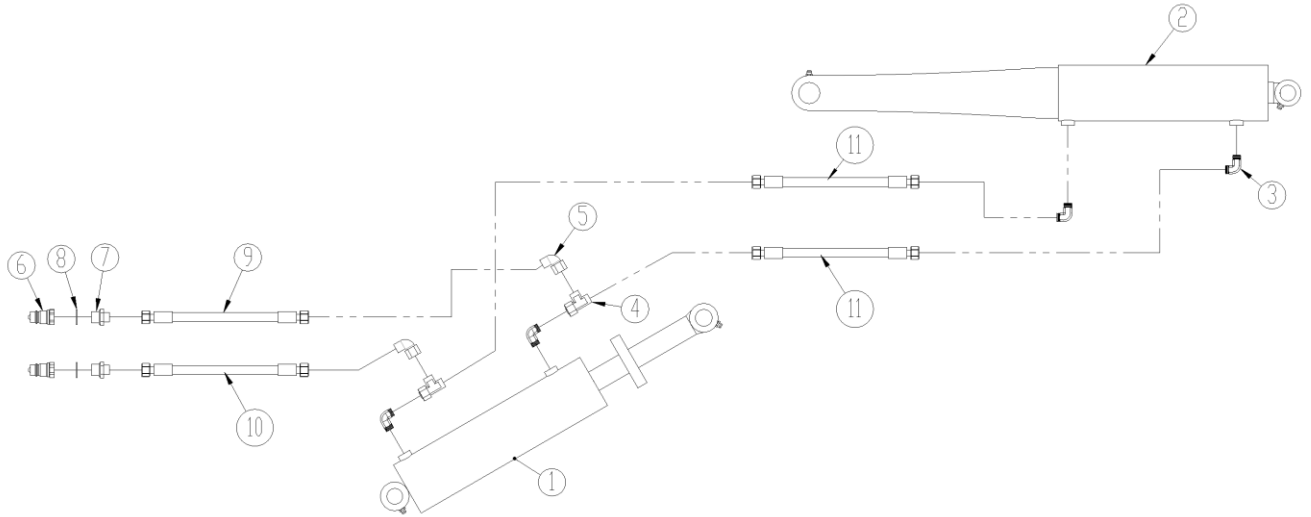

Pos.	Item no.	Designation	4,0m	5,0m	6,0m
1		See pos 23 page 18			
2		See pos 10 page 25			
3	0446200	Fitting 90 angel 3/8"	4	4	4
4	0446502	Fitting T Ø12mm	1	1	1
5	0446679	Fitting, 90angle Ø12mm	2	2	2
6	0444020	Quick coupling, male E402 ½"	2	2	2
7	690203103	Fitting, straight ½" Ø12	2	2	2
8	0449070	Bounded seal ½"	2	2	2
9	0454909	Hydraulic hose 3250 mm 3/8" st/st	1	1	1
10	0454835	Hydraulic hose 2950 mm 3/8" st/st	1	1	1
11	xxx	Hydraulic hose xxx mm 3/8" st/st	2	2	2

Recommends measuring hydraulic hose before re-ordering

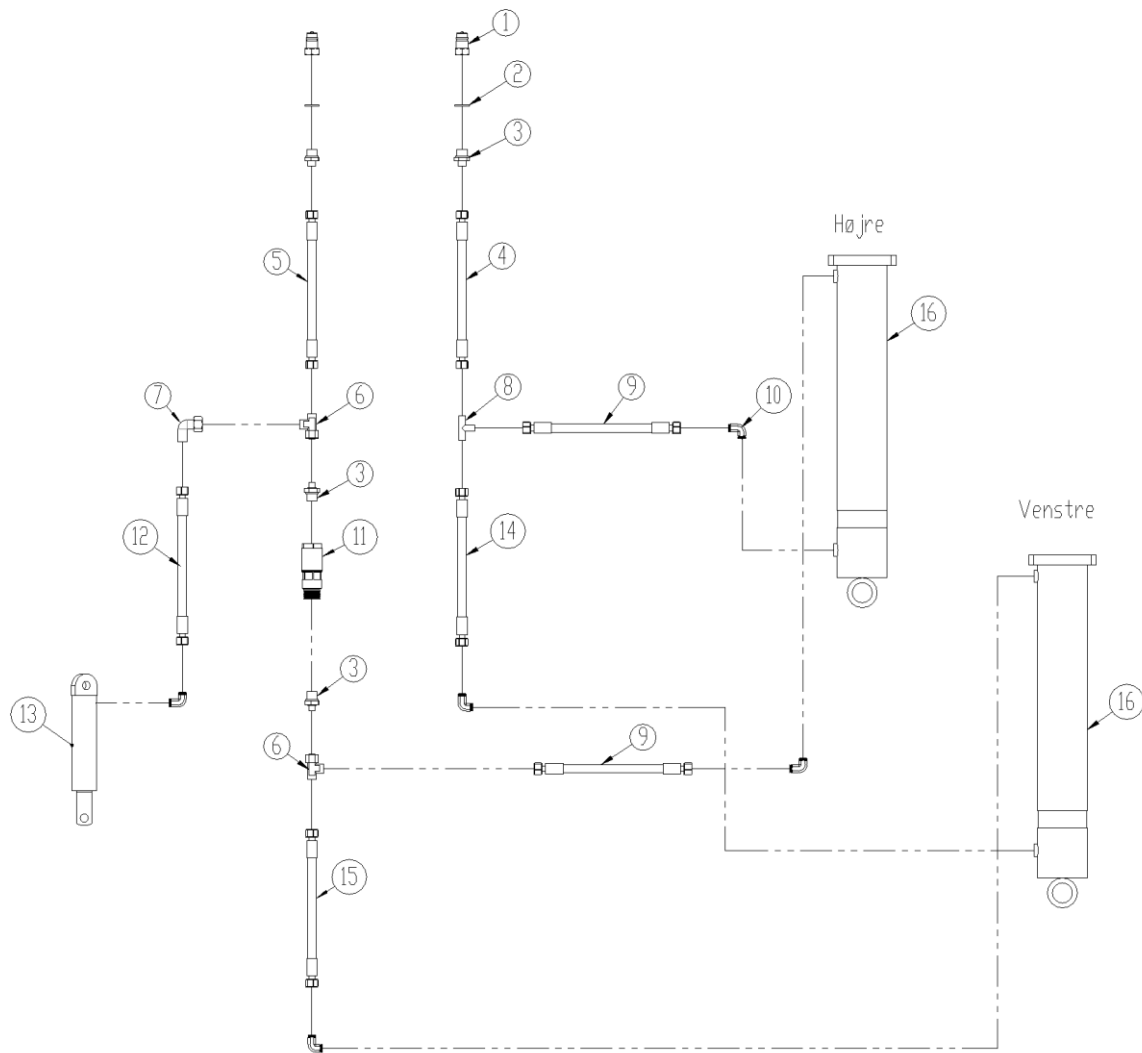
Wing

Pos.	Item no.	Designation	4,0m	5,0m	6,0m
1	0444020	Quick coupling, male E402 ½"	2	2	2
2	0449070	Bounded seal ½"	2	2	2
3	0446752	Fitting, straight 10-½" BSP	2	2	2
4	0454660	Hydraulic hose 2450mm ¼" st/st	1	1	1
5	0454645	Hydraulic hose 2300mm ¼" st/st	1	1	1
6	690203014	Fitting T10	2	2	2
7	0446678	Fitting 90angle 10 mm	1	1	1
8	690203015	Fitting T10	1	1	1
9	690201052	Hydraulic hose 935mm ¼" st/st	1	1	1
10	690203006	Fitting, 90angle 10-3/8" BSP	5	5	5
11	0442450	Sequential valve ½" m33X2 (145 bar)	1	1	1
12	0454645	Hydraulic hose 2300mm ¼" st/st	1	1	1
13		See pos. 36 page 22			
14	0454441	Hydraulic hose 1460mm ¼" st/st	1	1	1
15	690201009	Hydraulic hose 355mm ¼" st/st	1	1	1
16		See pos. 13 page 22			

Recommends measuring hydraulic hose before re-ordering

Disc-opens (rigid)

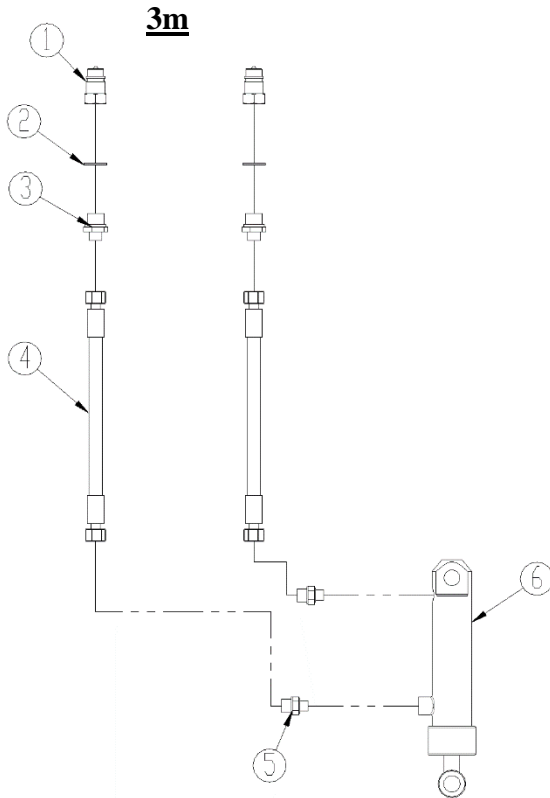

3.5m and 4m

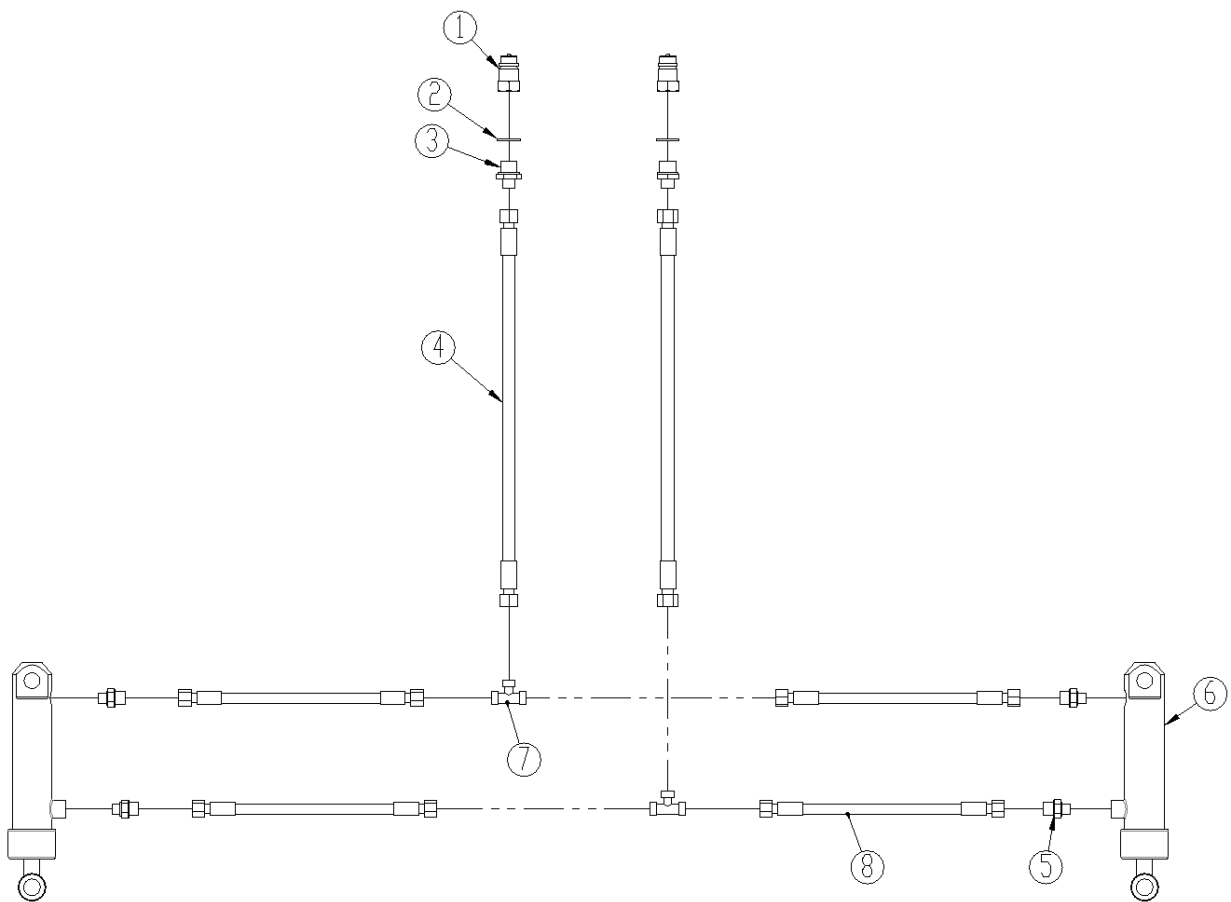

Pos.	Item no.	Designation	3,0m	3,5m	4,0m
1	0444020	Quick coupling, male E402 ½"	2	2	2
2	0449070	Bounded seal ½"	2	2	2
3	0446752	Fitting, straight 10-½" BSP	2	2	2
4	690201060	Hydraulic hose 3000mm ¼" st/st	2		
	690201060	Hydraulic hose 3000mm ¼" st/st (until 30/9 2024)		2	2
	0454577	Hydraulic hose 1950mm ¼" st/st (from 1/10 2024)		2	2
5	0446750	Fitting, straight 10-1/4"	2		
	0446750	Fitting, straight 10-1/4" (until 30/9 2024)		2	2
	0446750	Fitting, straight 10-1/4" (from 1/10 2024)		4	4
6		See pos 15 page 32			
7	690203015	Fitting T10		2	2
8	0454250	Hydraulic hose 1010 mm ¼" st/st		4	4

Recommends measuring hydraulic hose before re-ordering

Disc-opens (hydr)

4.0m and 5.0m

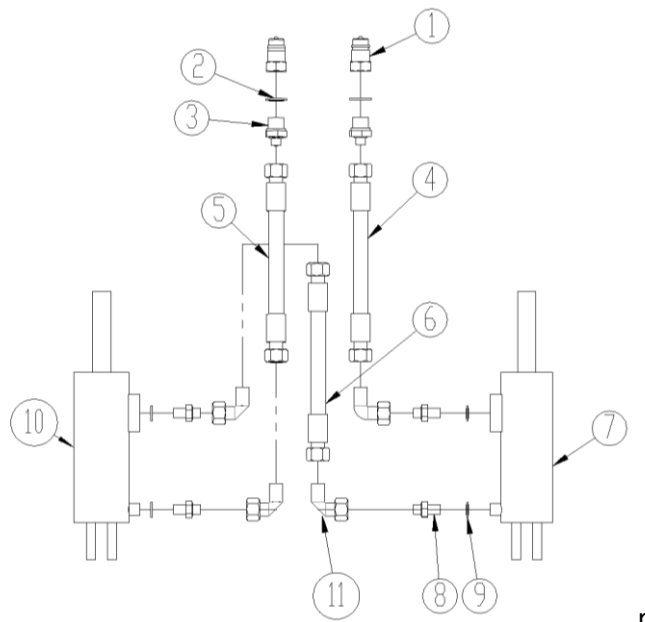

6.0m

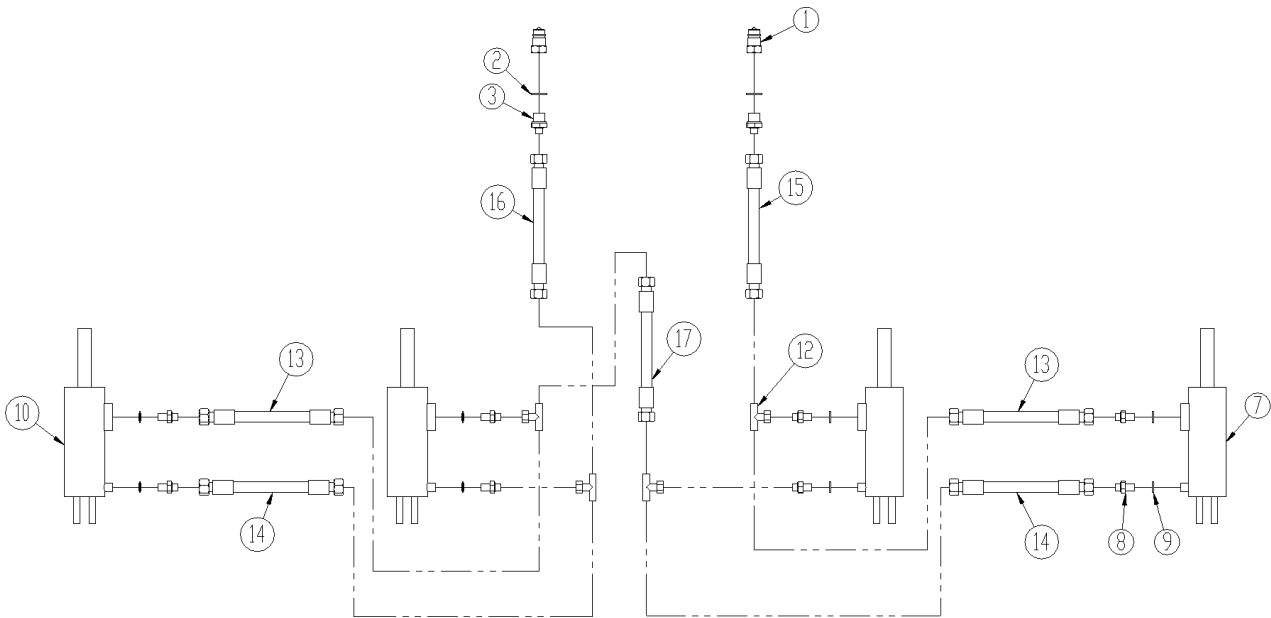

Pos.	Item no.	Designation	4,0m	5,0m	6,0m
1	0444020	Quick coupling, male E402 1/2"	2	2	2
2	0449070	Bounded seal 1/2"	2	2	2
3	0446752	Fitting, straight 10-1/2" BSP	2	2	2
4	0454967	Hydraulic hose 4200mm 1/4" st/st	1	1	
5	690201038	Hydraulic hose 4000mm 1/4" st/st	1	1	
6	690201038	Hydraulic hose 4000mm 1/4" st/st	1	1	
7		See pos 16 page 36			
8	0444501	Fittings, straight 1/4"	4	4	8
9	0449050	Bonded seals 1/4"	4	4	8
10		See pos 16 page 36			
11	0446650	Fitting, 90angle 1/4"	4	4	
12	0446610	Fitting T 1/4"			4
13	0454558	Hydraulic hose 1850mm 1/4" st/st			2
14	0454577	Hydraulic hose 1950 1/4" st/st			2
15	690201022	Hydraulic hose 3140mm 1/4" st/st			1
16	690201060	Hydraulic hose 3000mm 1/4" st/st			1
17	690201060	Hydraulic hose 3000mm 1/4" st/st			1

Recommends measuring hydraulic hose before re-ordering

Depth control of roller (rigid)

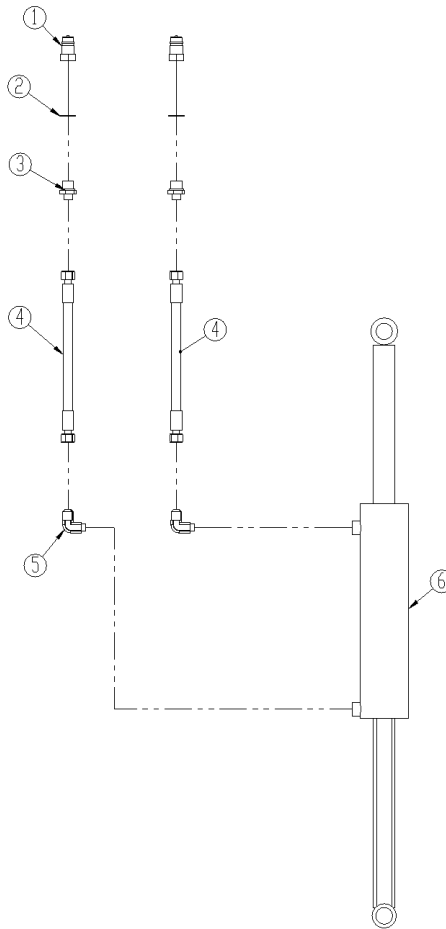

Pos.	Item no.	Designation	3,0m	3,5m	4,0m
1	0444020	Quick coupling, male E402 ½"	2	2	2
2	0449070	Bounded seal ½"	2	2	2
3	0446752	Fitting, straight 10-½" BSP	2	2	2
4	690201060	Hydraulic hose 3000 mm ¼" st/st	2	2	2
5	690203006	Fitting, 90angle 10-3/8" BSP	2	2	2
6		See pos 5 page 20			

Recommends measuring hydraulic hose before re-ordering

Depth control of roller (hydr)

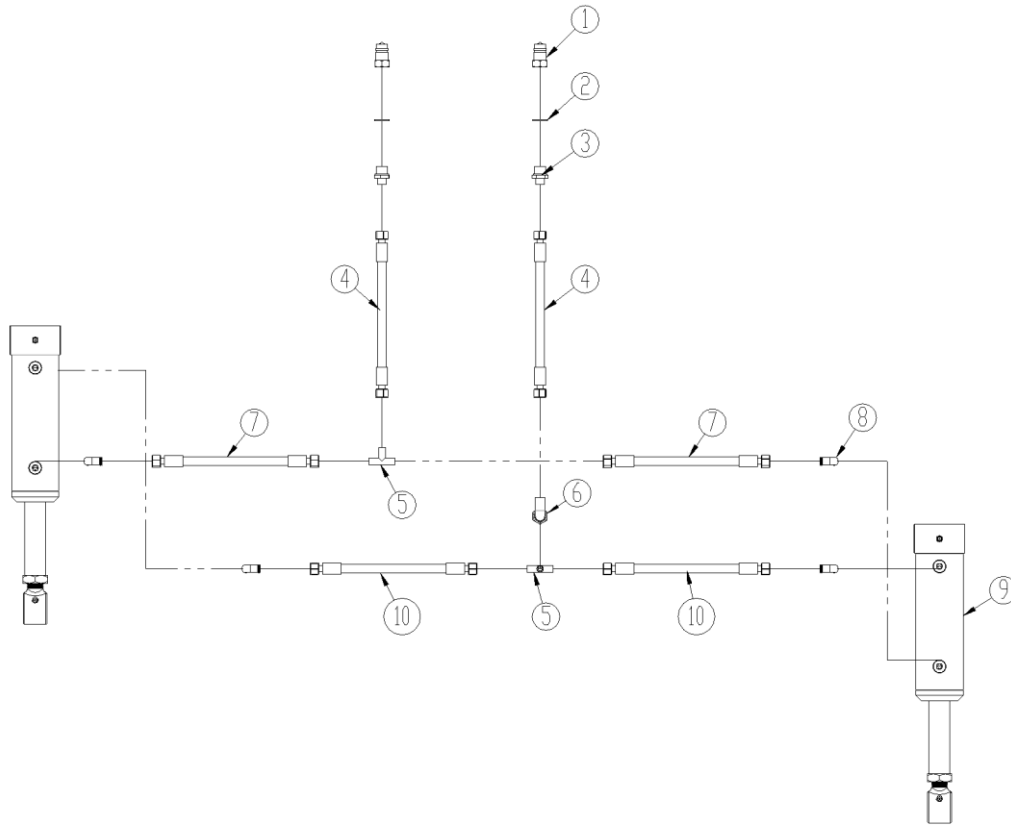

Pos.	Item no.	Designation	4,0m	5,0m	6,0m
1	0444020	Quick coupling, male E402 ½"	2	2	2
2	0449070	Bounded seal ½"	2	2	2
3	0446752	Fitting, straight 10-½" BSP	2	2	2
4	690201022	Hydraulic hose 3140mm ¼" st/st	2	2	2
5	690203015	Fitting T10	2	2	2
6	0446678	Fitting 90 angle 10 mm	1	1	1
7	0454577	Hydraulic hose 1950 mm ¼" st/st	2	2	2
8	690203006	Fitting, 90 angle 10-3/8" BSP	4	4	4
9		See pos. 21 page 22			
10	0454583	Hydraulic hose 2050 mm ¼" st/st	2	2	2

Recommends measuring hydraulic hose before re-ordering

Hydr. for automatic release system (rigid)

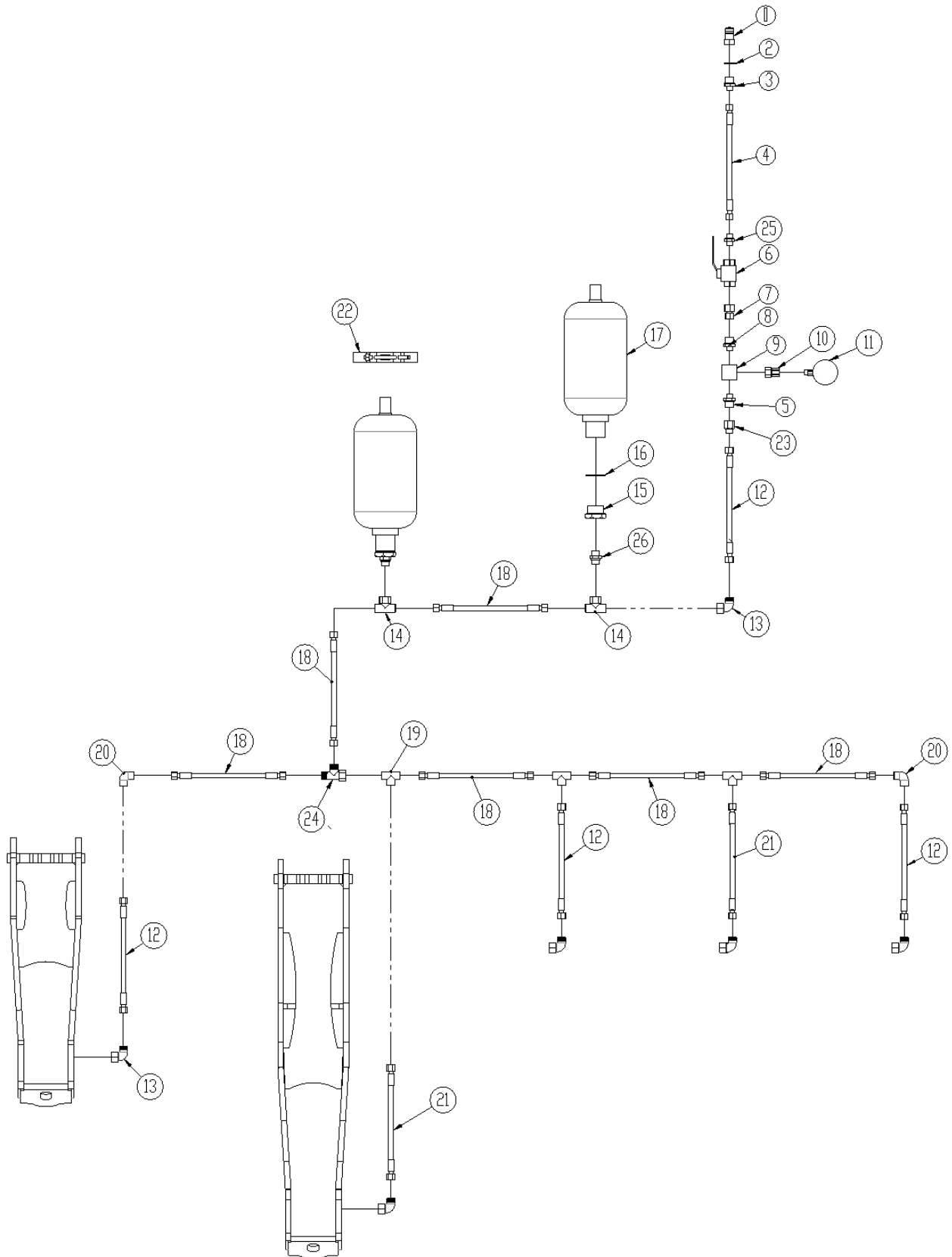

Pos.	Item no.	Designation	3,0m	3,5m	4,0m
1	0444020	Quick coupling, male E402 ½"	1	1	1
2	0449070	Bounded seal ½"	1	1	1
3	0446752	Fitting, straight 10mm x ½ "	1	1	1
4	690201016	Hydraulic hose 1850 mm 1/4" st/st	1	1	1
5	0446756	Fitting, straight Ø15 x 3/8"	2	2	2
6	0442350	Ball valve ¾"	1	1	1
7	690203130	Fitting, straight 12mm x 3/8"	1	1	1
8	0446754	Fitting, straight 12mm x 3/8"	1	1	1
9	660501410	Flowdiwider	1	1	1
10	690206825	Pressure gauge fitting Ø12 / 1/4"	1	1	1
11	0442051	Pressure gauge 400 bar	1	1	1
12	690201423	Hydraulic hose 500mm ½" st/st (Short tine bracket in the middele of the machine)			
	690201449	Hydraulic hose 850mm ½" st/st (Short tine bracket on the outside of the machine)			
13	0446680	Fitting, 90angle 15mm			
14	690204505	Fitting T 15mm	2	2	2
15	690204501	Fitting, straight 1/2" x 1 1/4" (until machine nr 39164)	2	2	2
	0446720	Fitting M22x1,5 x 3/4" (from machine nr 39165)	2	2	2
16	0449110	Bonded seals Ø1 1/4"	2	2	2
17	690206513	Accumulator 4,5L 110 bar (until machine nr 39164)	2	2	2
	690206515	Accumulator 6,0L 110 bar (from machine nr 39165)	2	2	2
18	690201414	Hydraulic hose 400mm ½" st/st			
19	690204507	Fitting T Ø15			
20	0446240	Fitting, 90angle Ø15			
21	690201449	Hydraulic hose 850mm ½" st/st (long tine bracket in the middele of the machine)			
	690201453	Hydraulic hose 1060mm ½" st/st (long tine bracket on the outside of the machine)			
22	690206516	Clamp f/accumulator	2	2	2
23	0447510	Fitting 15mm	1	1	1
24	0446500	Fitting T 15mm	1	1	1
25	0446751	Fitting ø10 x 3/8"	1	1	1
26	0446757	Fitting, straight ø15mm x ½ "	2	2	2

Recommends measuring hydraulic hose before re-ordering

Hydr. for automatic release system (hydr)

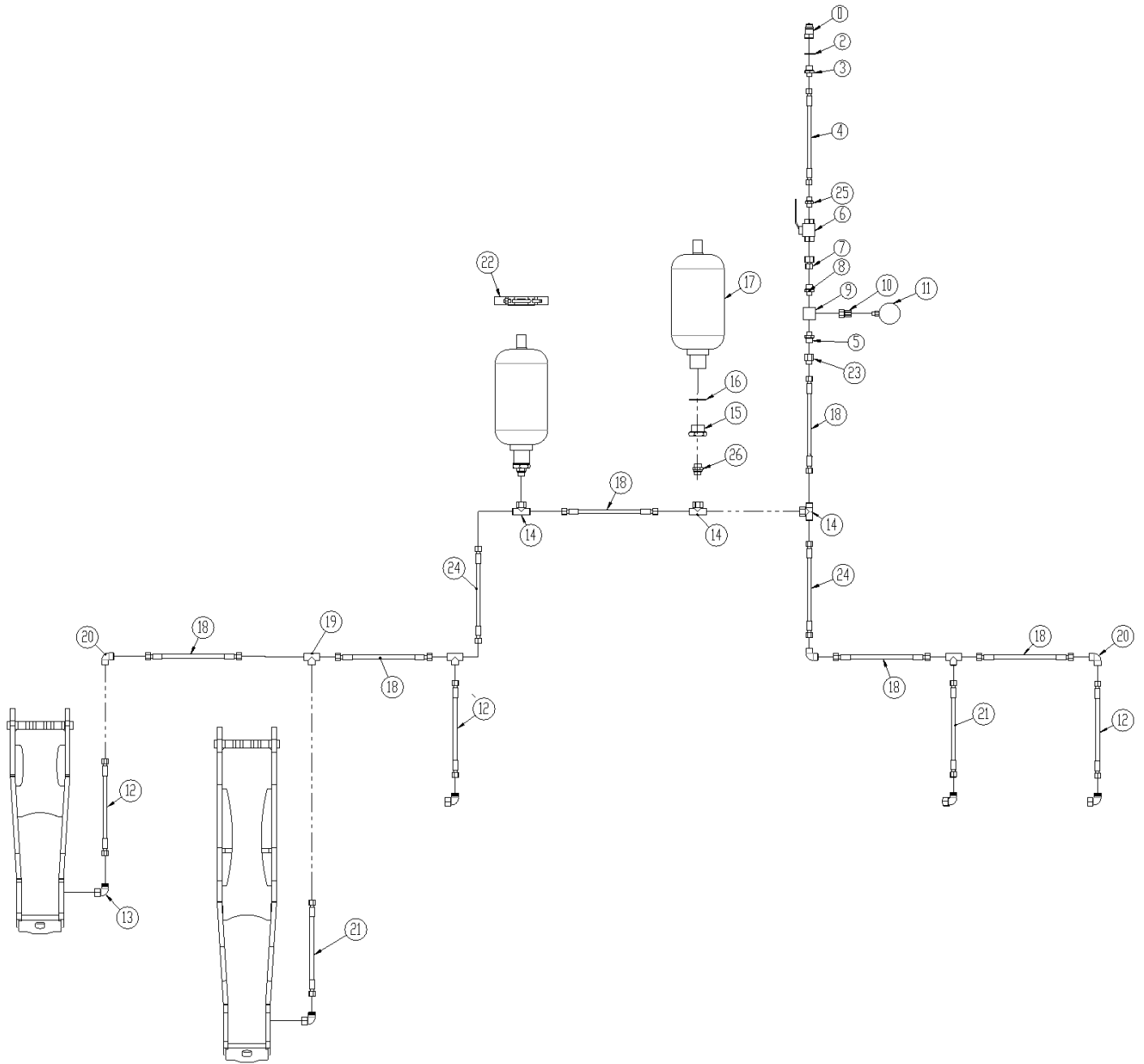

Pos.	Item no.	Designation	4,0m	5,0m	6,0m
1	0444020	Quick coupling, male E402 ½"	1	1	1
2	0449070	Bounded seal ½"	1	1	1
3	0446752	Fitting, straight 10mm x ½ "	1	1	1
4	0454645	Hydraulic hose 2300 mm 1/4" st/st	1	1	1
5	0446756	Fitting, straight Ø15 x 3/8"	2	2	2
6	0442350	Ball valve ¾"	1	1	1
7	690203130	Fitting, straight 12mm x 3/8"	1	1	1
8	0446754	Fitting, straight 12mm x 3/8"	1	1	1
9	660501410	Flowdiwider	1	1	1
10	690206825	Pressure gauge fitting Ø12 / 1/4"	1	1	1
11	0442051	Pressure gauge 400 bar	1	1	1
12	690201423	Hydraulic hose 500mm ½" st/st (Short tine bracket in the middele of the machine)			
	690201449	Hydraulic hose 850mm ½" st/st (Short tine bracket on the outside of the machine)			
13	0446680	Fitting, 90angle 15mm			
14	690204505	Fitting T 15mm	3	3	3
15	690204501	Fitting, straight 1/2" x 1 1/4" (until machine nr 39164)	2	2	2
	0446720	Fitting M22x1,5 x 3/4" (from machine nr 39165)	2	2	2
16	0449110	Bonded seals Ø1 1/4"	2	2	2
17	690206513	Accumulator 4,5L 110 bar (until machine nr 39164)	2	2	2
	690206515	Accumulator 6,0L 110 bar (from machine nr 39165)	2	2	2
18	690201414	Hydraulic hose 400mm ½" st/st			
19	690204507	Fitting T Ø15			
20	0446240	Fitting, 90angle Ø15			
21	690201449	Hydraulic hose 850mm ½" st/st (long tine bracket in the middele of the machine)			
	690201453	Hydraulic hose 1060mm ½" st/st (long tine bracket on the outside of the machine)			
22	690206516	Clamp f/accumulator	2	2	2
23	0447510	Fitting 15mm	1	1	1
24	690201449	Hydraulic hose 850mm ½" st/st	2	2	2
25	0446751	Fitting ø10 x 3/8"	1	1	1
26	0446757	Fitting, straight ø15mm x ½ "	2	2	2

Recommends measuring hydraulic hose before re-ordering

Plateau

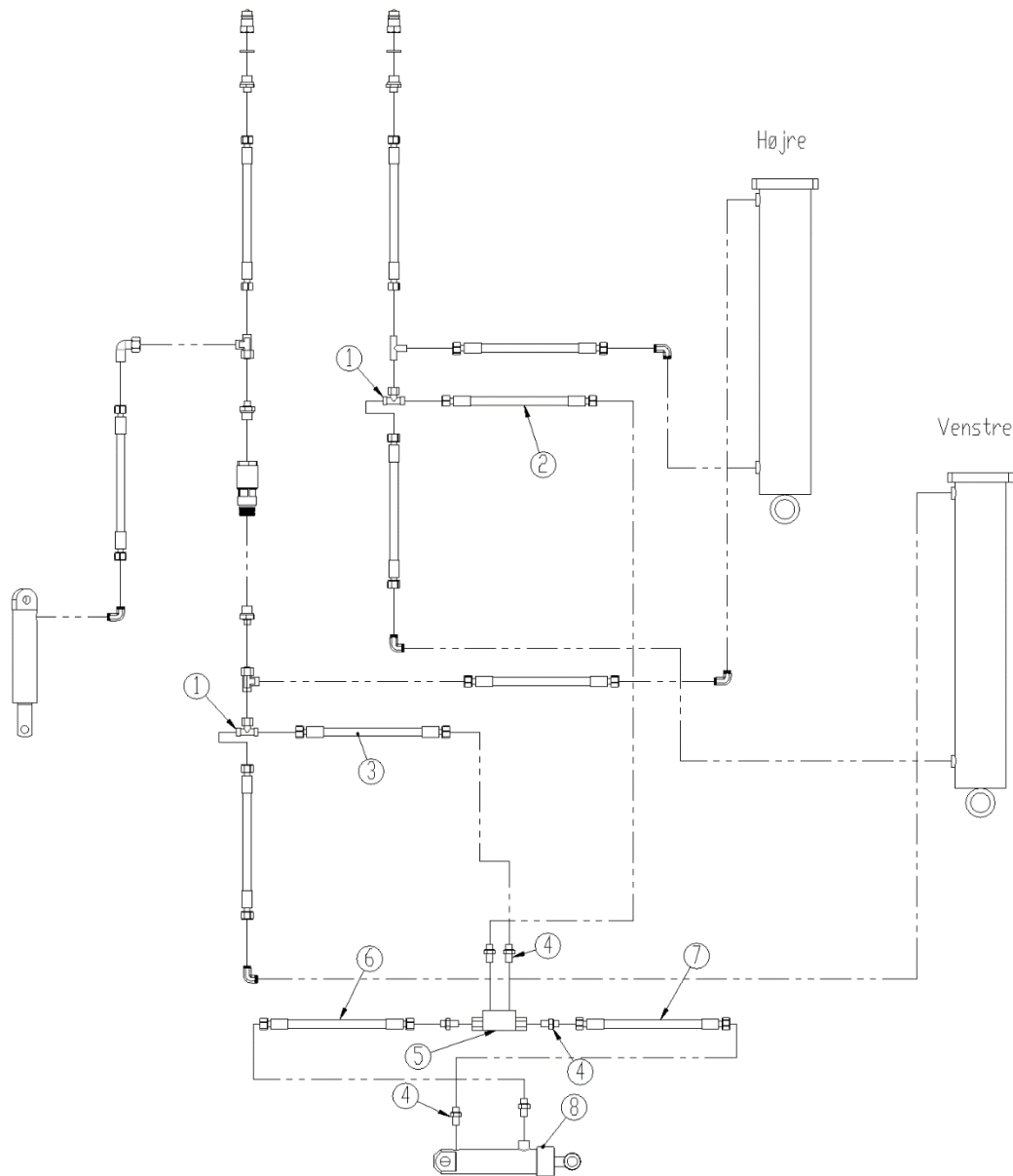

Pos.	Item no.	Designation	4,0m	5,0m	6,0m
1	690203014	Fitting T10	2	2	2
2	0454215	Hydraulic hose 820 mm 1/4" st/st	1	1	1
3	690201052	Hydraulic hose 935 mm 1/4" st/st	1	1	1
4	0446750	Fitting, straight 10-1/4"	6	6	6
5	0442500	Check valve pilot-controlled, double 1/4"	1	1	1
6	690201060	Hydraulic hose 3000mm 1/4" st/st	1	1	1
7	690201060	Hydraulic hose 3000mm 1/4" st/st	1	1	1
8	0468200	See pos.10 page 40			

Recommends measuring hydraulic hose before re-ordering

Notes

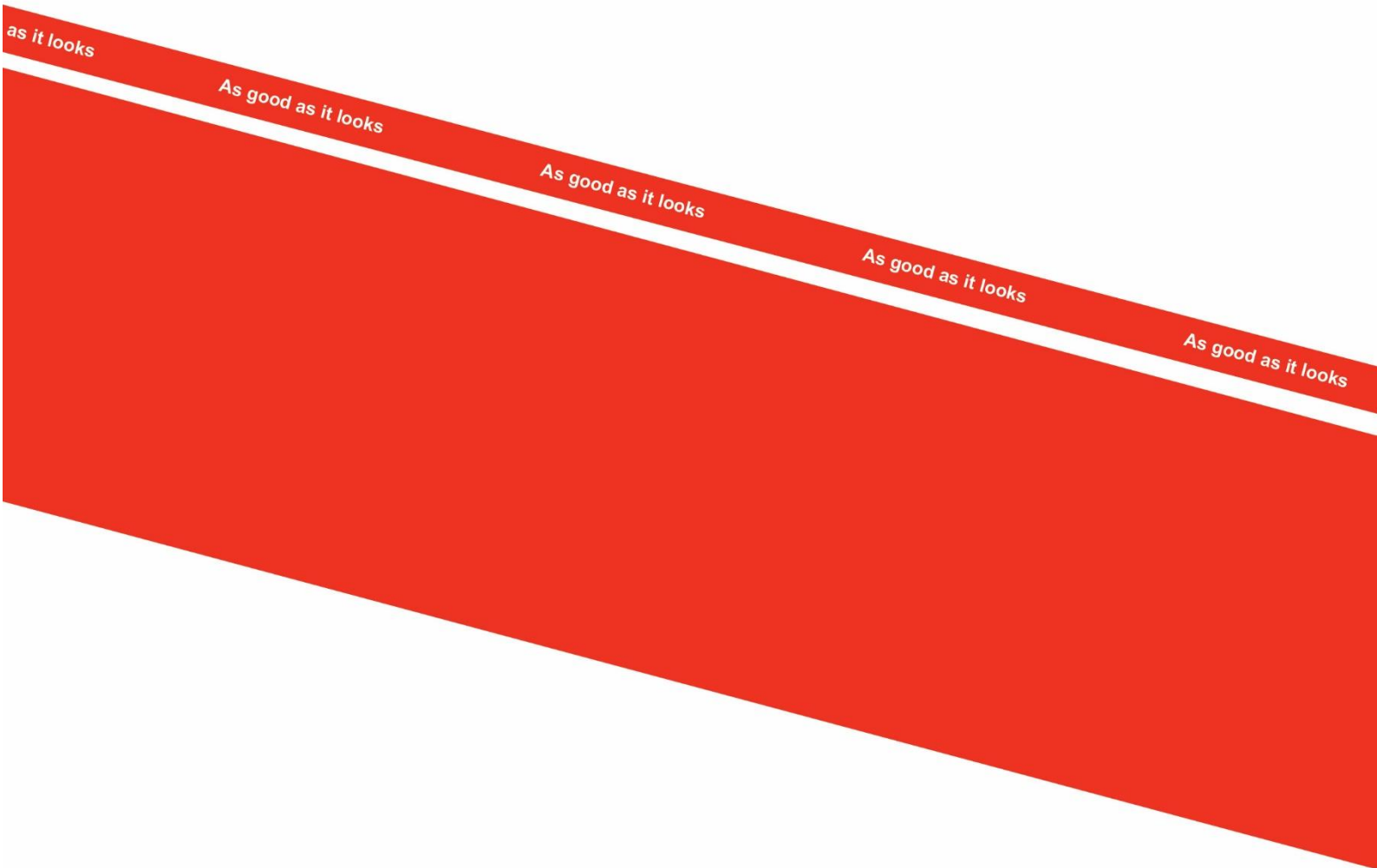

2011
Denmark